

SADAF ELECTRIC INDUSTRIES CO.



EARTHING AND LIGHTNING



THE COMPLETE PROTECTION

For Every Application and Industry

Universal Expert
For Your
Perfect Electrical
Infrastructure & Safety

www.seico-sa.com



Why do we need Earthing & Lightning protection? An exposed system of resources is vulnerable to unwanted sources of current and voltage, including the most severe interference. This interference is the Lightning currents.

When lightning strikes, it will be a high risk to the fabric of the building and the people plus equipment in it. That is why it is very important to capture this unwanted source and disperse it to the ground through a conductor network based on Faraday's Cage principle.

This is where Earthing Protection System support is dissipating the current to the mass of the earth. So, to overcome this disastrous electrical phenomenon, a comprehensive protection system that is explained and expressed in standard, is necessary. The current standard series of IEC/EN 62305 and UL are internationally coordinated standards and provide the said comprehensive overall concept for lightning, earthing and surge protection.



GENERAL INDEX

01	COMPANY BACKGROUND
	WHY SEICO EARTHING AND LIGHTNING?
02	TECHNICAL EXPERTISE AND SUPPORT
03	MAJOR PROJECTS
08	LIGHTNING PROTECTION SYSTEM
16	CONDUCTORS
36	EARTHING PROTECTION SYSTEM
60	EXOTHERMIC WELDING SYSTEM

You Can Find us AT:

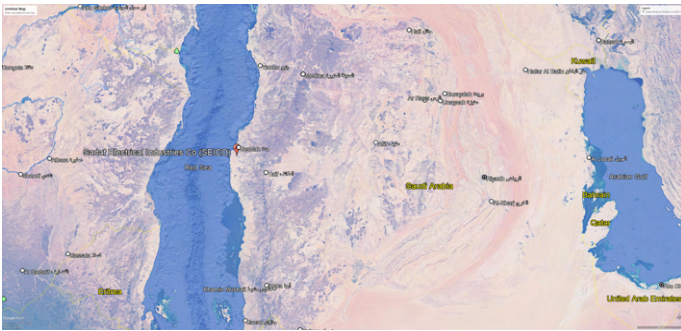

Instructions:

1. On your compatible Android/iPhone or tablet, open the built-in camera app / QR code scanner app / Google Lens.
2. Point the camera at the QR code.

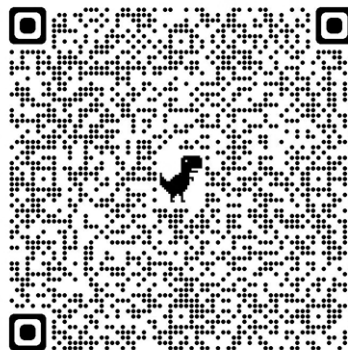

3. Tap the banner that appears on your Android phone or tablet.
4. Follow the instructions on the screen.

SCAN THIS QR CODE FOR LOCATION



A NECESSARY SAFETY SOLUTION FOR EVERY APPLICATION AND INDUSTRY

The function of Earthing & Lightning protection systems is to intercept and disperse lightning strikes. With **SEICO** systems and solutions, buildings structures, loss of services & data, factory equipment, security & electronic systems and people, are safe from lightning strikes.

Why Choose SEICO Earthing & Lightning Protection?

SEICO is a top leading supplier of Earthing & Lightning systems in Saudi Arabia and the GCC. Our dedication to providing ultimate services has earned us the trust of our clients. We promise fast lead time, cost-effectiveness and quick service response. We have been serving the market for more than 25 years. The company's factories in Saudi Arabia consist of integrated Cable Management Systems, Earthing & Lightning plants and Cable glands plants.

IEC/UL & ISO 9001

QUALITY PRODUCTS

Our design and R&D have broken new ground in Earthing & Lightning Protection System.

The Design and Quality of every single product are overseen by SEICO.

CERTIFICATIONS:

- BS EN 62561-1
- BS EN 62561-2
- BS EN 62561-4
- BS EN 62561-5
- UL 96
- UL 467
- UL 486



SINCE 1990

APPROVED VENDOR

Most of the Gulf countries such as Saudi Arabia, Qatar, Kuwait, Bahrain and UAE.

Some of the entities we are approved with:

- ARAMCO
- NEOM
- RED SEA
- SABIC
- SEC
- ADNOC - UAE
- SWCC
- GASCO
- PETROFAC
- KOC - KUWAIT
- QATAR PETROLEUM - QATAR
- NHC- Ministry of Housing and other Governmental bodies

IN-HOUSE PROCESSES

INTEGRATED SOLUTIONS

- Galvanizing & Painting Lines
- Aluminium & Brass Casting
- Copper & brass extrusion
- CNC & VMC machines
- Dies & tools design and creation

Internal Control & Tests:

- Internal Metallurgy
- Mechanical Tests
- Chemical Tests
- Electric Tests

Benefits of Choosing SEICO Earthing & Lightning Protection Systems

- **SEICO's** Lightning Protection Systems protect against all potential risks from a direct lightning strike and are designed to deliver effective and complete external lightning protection.
- **SEICO's** structural lightning protection system protects the entire structure including all equipment inside, by channelling lightning strike energy in a safe and controlled manner to an earth termination network for dissipation.
- **SEICO's** professional lightning protection system connects lightning energy to the down conductor network at the base of the building. This allows lightning current to dissipate harmlessly into the earth.
- **SEICO's** equipotential bonding is designed so that dangerous sparking or flash-over events do not occur within a structure or building.
- **SEICO** systems design ensure that no metal parts will conduct electricity from lightning (should it strike a building) and no human life will be endangered during the event.
- Protects against power surges or transient over-voltages.



360° Technical Support



SEICO is proud to offer expert advice as well as top-quality solutions for many of today's electrical and lightning-related problems in the Gulf Cooperation Council.

Protection from Lightning



- Many years of experience
- Client-focused engineering services
- Risk assessment services for business

Soil Resistivity

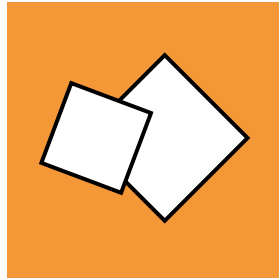

- Experienced and trained professionals
- All tests are taken more than once for accuracy
- Complete safety earthing systems

Design and Analysis



- Reports customized to the client's needs
- Latest technology and software for design

Testing Services

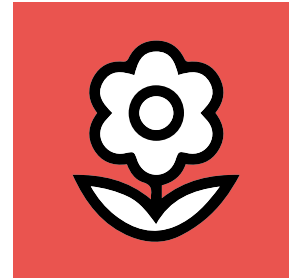

- Our team of professionals understands all testing requirements
- All testing is properly verified on site

The Complete Lightning Surge Protection

Our professionals require specific information to give you the maximum lightning protection for your business.

This includes:

- Single line diagrams for all electrical systems, including current, voltage and locations. This includes alarm, data, and communications systems.
- What standards do you require? (NFP780 for example)
- A plan of your roof and surrounding elevations
- What materials is your building made of? Please list all materials including roofing.
- Important details on computer systems, servers, and networks

On-Site Surveys

When you blend the benefits of one-site surveys with a professional in-house design you receive complete solutions to your lightning surge problems. We offer complete custom earthing design for your business including all the necessary testing, plans, and calculations and you will be provided with a detailed report of all findings along with detailed professional advice.

Do You Need a Power Earth Electrode (Earthing Rod) System?

We can design your system so it meets all your needs but we will require:

- Design standard and dimensional site plan
- Testing results (soil resistivity)
- Earth fault current information
- Earth fault current magnitude - this should be done by a trained professional because it requires many important considerations, including overhead power lines.
- Earth fault current duration

6 Reasons to Choose SEICO

You will enjoy a wide range of benefits when you choose SEICO for protecting all aspects of your business and property:

1. All standards are fully complied with
2. Expert advice from seasoned professionals
3. Design services customized to all your needs
4. Quality products and services
5. Your safety is our biggest concern
6. Our engineers are active participants in developing the latest standards for electrical safety.



SEICO is proud to serve the oil and gas, commercial, government, transportation industries, and many other businesses, with innovative solutions to power surges and over-voltage prevention. Thanks to our services, thousands of people can work in safer environments. Here are some projects we have undertaken, to keep these businesses safe and running smoothly without needless interruptions.

MAJOR PROJECTS:

OIL & GAS

- Shuqaiq Power Plant
- Borouge 2 Project
- QAFCO Expansion Project
- Yanbu Export Refinery Project YERP
- Jazan Refinery
- Jazan Integrated Gas Combined Cycles
- New Booster at West Kuwait, KOC - Kuwait
- New Gathering centre, KOC - Kuwait

COMMERCIAL

- Jabal Omar
- Mutrafiah Housing Project
- Jazan Housing
- KAP 2A
- KAUST Housing
- King Khalid International Airport (T5)
- Najran Housing
- Thakher City Development Project
- The Infrastructure of Residence in Hafr AL Batin

POWER & UTILITIES

- Qurayyah power plant
- Jeddah South power plant
- Shuqaiq power plant
- Power Plant 12 & 13
- Fadhile OHTL
- AL Waha and AL Wajh - 380 KV Substation

INDUSTRIAL

- Maaden Phosphate Project
- SADARA

TRANSPORTATION

- General Authority of Civil Aviation
- Riyadh Metro

HOSPITAL

- AL Salam Hospital
- Dr. Soliman Fakeeh Hospital
- King Fahad Central Hospital

A COMPLETE RANGE OF PROTECTION AND CONTROL DEVICES

1. Conductors

In an effective lightning protection system, lightning current can be grounded safely with the right conductors. When designing a structural lightning protection system, the material and current density in relation to the fault current duration and decisive for the selection of the earthing conductor cross-section. The selection of the right conductor type for the installation is important and, hence, the designer has to make the right choice, as follows.

- Choose the material required, i.e., copper (BS EN 13601) or Aluminium (BS EN 755-5)
- Choose the type of conductor required, i.e., flat copper, solid circular or stranded.

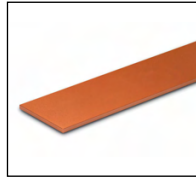

2. Fixing

Each part of the conductor system should then be paired with the appropriate type of fixings. SEICO fixings are available for installation in a variety of construction materials, including brick, stone, metal and plastic.

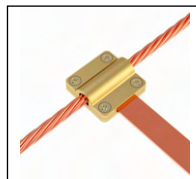

3. Air Termination Network

An air termination network is the point of collection of a lightning strike, connecting in the form of a mesh conductor system covering the roof of the building. Lightning protection level (or LPL) will determine the proper mesh size.



4. Air Terminal

For the protection of rooftop equipment or other prominent features, use vertical air rods. Strike pads are designed to provide an exposed attractive point on an embedded conductor system. (e.g., below the tiles)



5. Air Rod Base

The correct air rod base should provide a low resistance connection to the conductor network, while at the same time, ensuring that the air rods are securely attached to the fabric of the earthing structure.



6. Flexible/Bond Components

Components must be selected for changes in direction or so multiple conductors can be connected. Jointing clamps will provide a low-resistance connection from the air termination and down conductors without the risk of any corrosion.

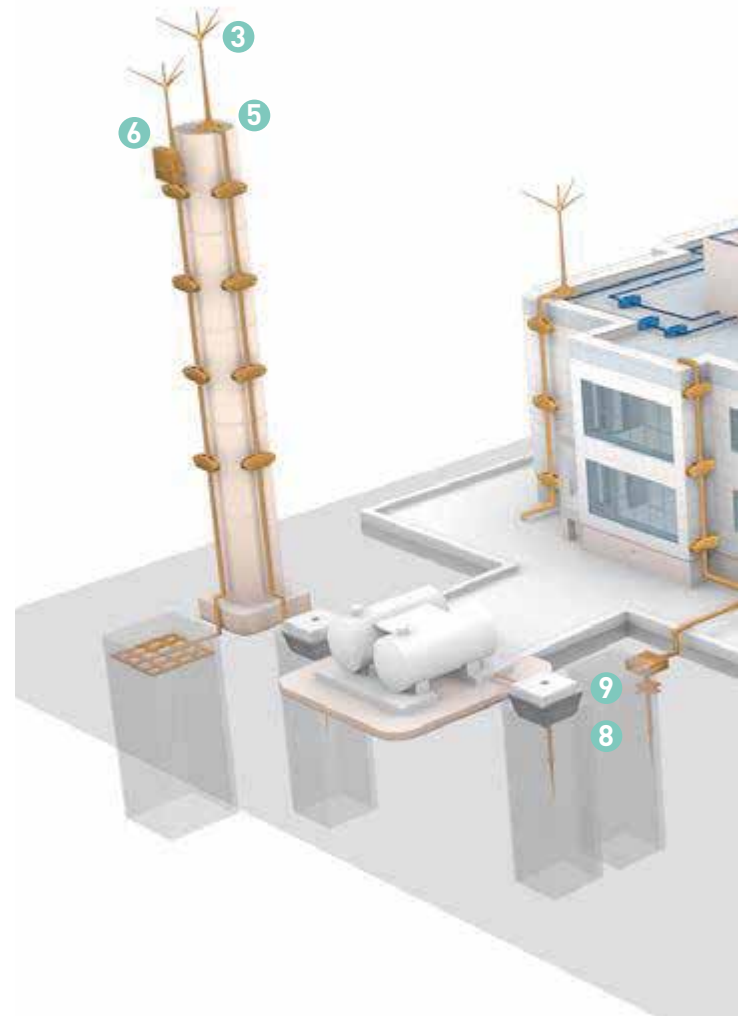
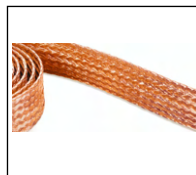

7. Square Test Clamps

A test clamp should always be installed within the run of each down conductor, providing a convenient option for periodic disconnection and testing of each termination network.



8. Earth Electrodes

Earth electrodes (such as Type A, Type B or foundation electrodes) should be suitable for the design of the lightning protection system. Earth electrodes can be earth rods, earth plates, stranded cable, flat tape, or a combination of several of these components.



9. Earth Rod Clamps

Earth rods should be connected to the earthing conductor by an alloy earth rod clamp (with high copper content). As with any below-ground installation, the clamp must provide low earth resistance without the possibility of corrosion.



10. Earth Inspection Pits

Earth inspection pits are designed to protect earth electrode connections. Both plastic and concrete can be used as high-strength pits.



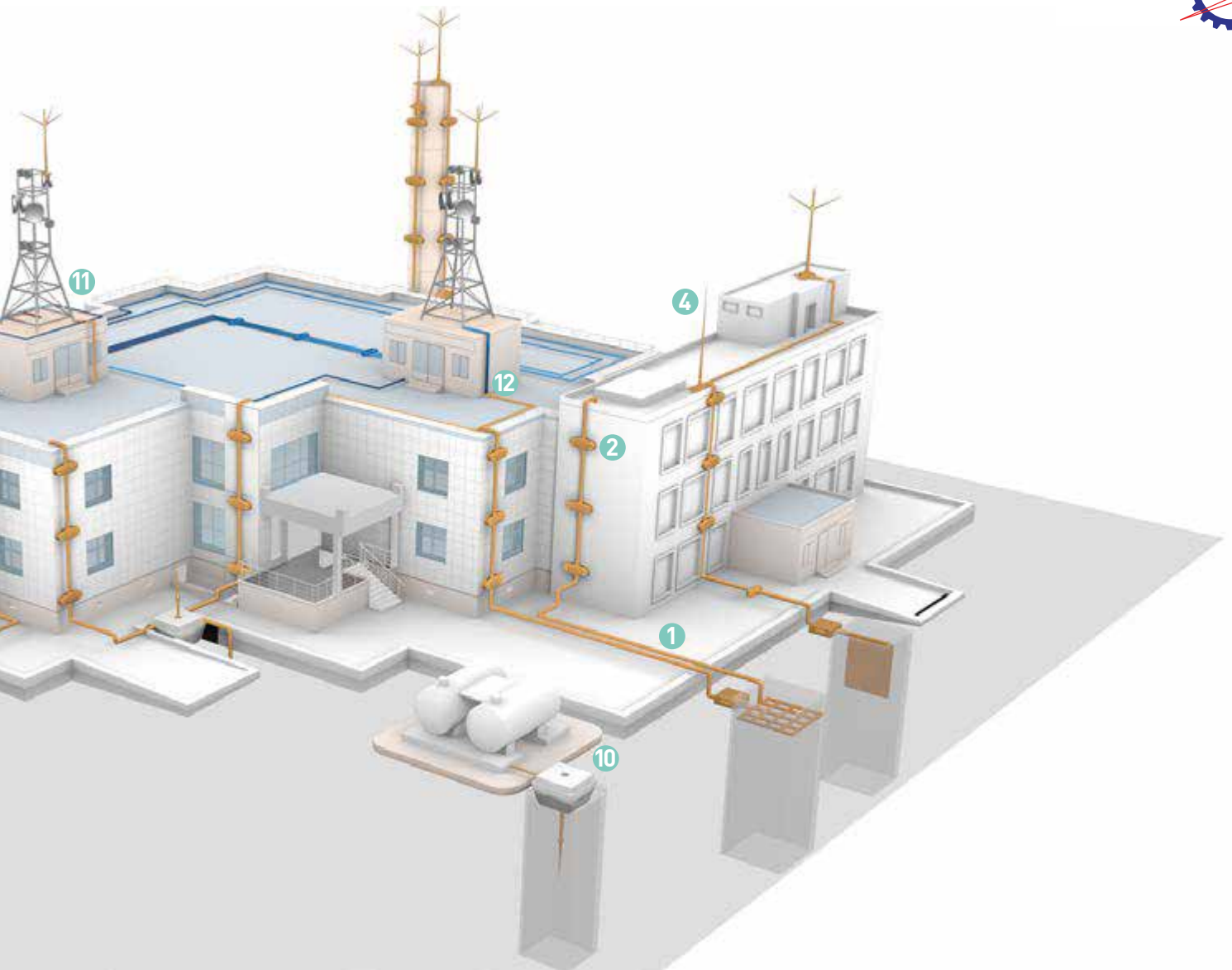

11. Equipotential Bonding

Bonding is the most common option for preventing damage by side flashing. One should consider bonding any continuous metal work, and any metallic systems entering the structure (such as cable armouring and gas, water or steam piping). Bonding should be done to the earth termination network as directly as possible.



12. Bonds To Metalwork

The correct type of metalwork bond (such as a flat column face, circular rainwater pipe or ribbed reinforcing bar) should be used for each specific application.

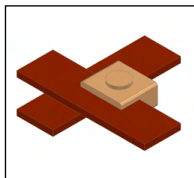

THE ILLUSTRATION IS FOR DEMONSTRATION ONLY. IT DOES NOT REPRESENT LIGHTNING CONDUCTORS OR EARTHING SYSTEMS MEETING ANY SPECIFICATION OR STANDARD CODE OF PRACTICE.

Product Selection Key - LPS

	Page
01 Conductor	16
02 Fixing	24
03 Air Termination Network	12
04 Air Terminal	10
05 Air Rod Base	12
06 Flexible/Bond Components	50
07 Square Test Clamps	32
08 Earth Electrodes	36
09 Earth Rod Clamps	43
10 Earth Inspection Pit	40
11 Equipotential Bonding	45
12 Bond to Metal Work	60



LIGHTNING PROTECTION SYSTEM
CONDUCTORS
EARTHING PROTECTION SYSTEM
EXOTHERMIC WELDING SYSTEM

SEICO offers components and devices for the complete solution of earthing and lightning protection systems, as noted in the following pages. All of them conform to BS EN 62561 which ensures that when installed would have the requisite durability to survive long-term exposure to the environmental elements while retaining the ability to disperse the lightning current safely to earth.



SYSTEM INDEX

- 08 LIGHTNING PROTECTION SYSTEM**
Contains important product details and brief explanations of what is required for a proper lightning earthing structural system installation.
- 16 CONDUCTORS**
Includes the most common conductors used (i.e. flat tapes and stranded).
- 36 EARTHING PROTECTION SYSTEM**
Complete descriptions of materials for SEICO Earthing Systems, including design features.
- 60 EXOTHERMIC WELDING SYSTEM**
Exothermic systems are very important for increasing corrosion resistance on a molecular level. They are often seen in a large array of applications including grounding, earthing, cathodic and lightning protection.

LIGHTNING PROTECTION SYSTEM

A lightning protection system is designed to protect a structure or building (or its contents) from damage by extremely high voltage currents from a lightning strike. It offers lightning strikes, and a low resistance path to the ground (where this enormous energy is then safely dispersed). A typical lightning protection system includes lightning rods, bonding conductors and ground electrodes. This is designed to offer a low path of resistance to the ground and takes any high voltage currents from a lightning strike away from the structure of the building.

Within a lightning protection system, lightning rods or air terminals are strategically situated on the structure to increase the chances of intercepting a lightning strike before it hits the property it's protecting.

Our Lightning Protection System will provide you with the following benefits:

- Prevents fatal injuries from lightning
- Limits the risk of loss of service to the public
- Protects against loss of cultural heritage
- Protects against business downtime

Lightning can be unpredictable and SEICO's well-designed lightning protection system; Consider this. Our system is designed so that even if lightning strikes the building's structure first, its extreme currents will be drawn into the lightning protection system before any serious damage or harm can be done to human life, cultural heritage, services to the public or loss of business income.

It's very important to understand that proper grounding is essential for efficiently and safely dispersing large amounts of energy from a lightning strike. Failure to provide adequate grounding will cause a lightning protection system to be ineffective, resulting in property damage and risk to human life.



Features:

- 1 Its components Comply with BS EN 62561-2 & UL 96
- 2 Simple to install
- 3 Manufactured from High conductivity, hard-drawn copper or Aluminium
- 4 Rolled threads on rods are available
- 5 Supplied complete with locknuts
- 6 Can be easily fixed by using countersunk wood screws and wall plugs
- 7 Bases are manufactured from high-quality alloys of either copper or aluminium



Structure Lightning Protection System vs Faraday's Law:

Based on the principles of the Faraday Cage, SEICO Designed Lightning Protection Systems can utilise a variety of materials as conductors. Copper, Aluminium flat tape, stranded copper cables or circular copper cables are all acceptable. These materials will work equally well, so geographical or historical preference will determine the decision, as well as aesthetic matters. In addition, all three systems can be used effectively with Seico's copper and Aluminium conductors and fittings.

Flat Tape Conductor System:

SEICO's flat tape conductors require no straightening, to provide a clean finish and an easy installation. Flat tape conductors are constructed from copper or Aluminium, although tinned copper is also an option for more comprehensive protection, and braided copper can also be used in moving installations (such as doors or gates) which require greater flexibility.

Flat tape conductors can be installed "as is" or with PVC jackets to complement the construction of the building. SEICO's copper tapes are manufactured in accordance with BS EN 13601, IEC / BS EN 62561-2 & UL 96, UL 467, UL 486 A-B regulations. In addition, our Aluminium tapes meet IEC / BS EN 62561-2 & BS EN 755-5 and UL standards.

Solid Circular Conductor System:

Solid circular conductors offer a kind of protection that is more subtle than its flat tape equivalent, with easily concealable 8mm diameter cabling. This makes the solid circular system an ideal choice for locations where aesthetics are important. Solid circular conductors are installed quickly, as they are uncoiled and manipulated into any area with ease. A straightening tool is all that is needed for a clean finish. SEICO's solid circular conductor systems are available in Aluminium

or copper, with the option of PVC covering. Our copper solid conductors meet BS EN 13601 standards and conform to BS EN 62561-2 & UL 96. Our Aluminium solid conductors are approved by BS EN 755-5 guidelines.

Stranded Copper Conductor System:

SEICO's stranded copper conductor systems can be installed either bare or with PVC coatings and still meet the requirements of the NFPA 780 US stranded. In addition, our soft-drawn stranded copper conductors are BS EN 60228 approved, whereas the PVC-covered stranded copper conductor meets BS EN 50525 criteria.



BS EN 62561-1, BS EN 62561-2 BS EN 62561-4
UL-96

AIR TERMINATION:

Air termination plays a vital role in lightning protection systems, capturing the fullness of the lightning strike current and channelling this current safely to the conductor network. This makes it very important to install a correctly designed air termination system.

SEICO's air termination products are specifically designed to provide highly effective protection against the risks and consequences of direct lightning strikes.

AIR ROD:

SEICO's air rods are manufactured from high conductivity hard drawn copper or aluminium, and provide an excellent and durable strike point for lightning. Supplied with locknuts and rolled threads, the air rods attach easily to our air rod bases.

CONDUCTOR CLIPS:

SEICO provides different types of clips to support our conductors (i.e. tapes or conductors). Clips are manufactured from high-quality alloys of either Copper or aluminium for excellent corrosion resistance and load capacities.

AIR ROD BASE, SADDLES & COUPLINGS:

SEICO's comprehensive range of air rod bases, conductor fasteners and clamps are manufactured from high-quality copper or Aluminium alloys, to ensure that a high level of conductivity is maintained throughout the air termination system. These components are robust enough to last a significant number of years on exposed roof lines, and they hold the conductor cable in place. All these components (base and coupling) link together with our copper or aluminium conductors, to provide a path of low resistance for lightning current from strike point to earth, safely.

CONDUCTOR CLAMPS:

Our conductor clamps are used to connect multiple conductors, and to ensure you receive low resistance, corrosion-resistant connections. They can be used to form straight connections, and cross or tee joints in tape. All clips are manufactured from high-quality alloys of either copper or aluminium. They are very easy to install and allow an effective low resistance connection between overlapping tapes. This provides the options of the cross, tee, through and right angle joints.

ACCESSORIES:

SEICO accessories can be used to create a cross, straight through or tee joints in standard copper conductors. These clips are manufactured from high-quality copper or aluminium alloys. Simple to install, our accessories provide an effective way to create low resistance connections for several materials.



Air Terminal Rod



Air Terminal Base



Air Terminal Multiple Point

Code
AT-L0-D8-C
AT-L1-D8-C
AT-L3-D8-C
AT-L5-D8-C
AT-L7-D8-C
AT-L9-D8-C
AT-L0-D8-A
AT-L3-D8-A
AT-L5-D8-A
AT-L7-D8-A
AT-L9-D8-A

Air Terminal Rod

Air Termination System

Conforms to IEC 62561-2 and UL 96

Air Terminal Rods are available in high conductivity copper or aluminium. The role of the air termination system is to capture the lightning, discharge current and dissipate it harmlessly to the earth termination system. Air Terminal Rods go along with some brackets, couplers, posts and optional multiple points.

- Manufactured from high-quality hard-drawn copper or aluminium, with rolled threads.
- Our air rods are supplied complete with locknut.

Rod Length (mm)	Rod Material	Weight (kg)	Rod diameter (mm)	Threadsize
500	Copper	0.73	Ø15	M16
600	Copper	0.88	Ø15	M16
1000	Copper	1.51	Ø15	M16
1500	Copper	2.35	Ø15	M16
2000	Copper	3.00	Ø15	M16
3000	Copper	4.70	Ø15	M16
500	Aluminium	0.29	Ø15	M16
1000	Aluminium	0.53	Ø15	M16
1500	Aluminium	0.80	Ø15	M16
2000	Aluminium	1.06	Ø15	M16
3000	Aluminium	3.20	Ø15	M16



ATB-D8-07-C
ATB-D8-07-A
ATB-D8-14-C

Air Terminal Base

Air Termination System

Conforms to IEC 62561-1 and UL 96

Air Terminal Base is made of copper alloy or aluminium. The air terminal base fixes onto the roof network of the lightning protection system and is used in connecting the air termination tape to the Air Terminal Rod.

- Manufactured from high-quality alloys of either copper or aluminium.
- Simple and easy to install, providing a reliable connection between air rod and air termination tape.

Fixing Hardware:

- Counter sunk screw size 1-1/2" x No.10 or M6
- Plastic Wall Plug size No.10

Material	Weight (kg)	Rod diameter (mm)	Thread size	Conductor width (mm)
Copper	0.43	Ø15	M16	25
Aluminium	0.14	Ø15	M16	25
Copper	0.7	Ø15	M16	50

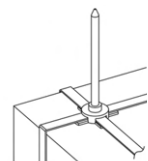

ATMP-D8-C
ATMP-D8-A

Air Terminal Multiple Point

Air Termination System

Conforms to IEC 62561-2 and UL 96

Made of Copper or Aluminium and used in conjunction with the copper air terminals. The Air Terminal Multiple Point is connected to the air termination network. Its main duty is to widen the range of protection.

- Manufactured from high quality hard-drawn copper or aluminium.
- Simple to fix at the air rod.
- Suitable for use with 15 mm diameter air rods.

Air Rod Diameter (mm)	Weight (kg)	Air rod Material
Ø15	0.27	Copper
Ø15	0.10	Aluminium





Air Terminal Ridge Saddle

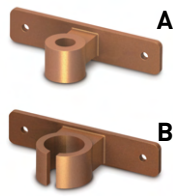

Rod Brackets



Air Terminal Rod to Tape Coupling



Air Rod to conductor coupling

Code **Air Terminal Ridge Saddle**

Air Termination System

Conforms to IEC 62561-1 and UL 96

Made of copper alloy, the air terminal ridge saddle is fixed onto the roof network on the ridges, connecting the tape or conductors to the air terminal rod.

The air terminal saddle has a thread of M16 or 3/4" to suit the air terminal rod.

- Manufactured from high-quality alloys either copper or aluminium.
- Simple to install, providing an effective fixing for lightning conductor air rods on ridges

Fixing Hardware:

- Counter sunk screw size 1-1/2" x No.10 or M6
- Plastic Wall Plug size No. 10
- Tightening Torque 15N-m

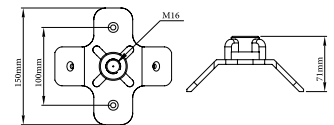

	Air Rod Diameter (mm)	Max. Conductor Width (mm)	Weight (kg)	Conductor material	Thread size
ATRS-D8-10-C	Ø15	31	1.07	Copper	M16
ATRS-D8-10-A	Ø15	31	0.45	Aluminium	M16

Air Terminal Rod Fixing Bracket

Air Termination System

Conforms to IEC 62561-1 and UL 96

- Made from copper or aluminium alloys.
- Air terminal brackets are fitted on the side of the building or chimney stack and used in conjunction with an air terminal rod-to-tape coupling or Rod to conductor coupling.

Fixing Hardware:

- Counter sunk screw size 1-1/2" x No.12 or M8
- Plastic Wall Plug size No. 12

	Material	Weight (kg)	Air rod diameter (mm)
ATFB-D8-C-A	Copper	0.90	Ø15
ATFB-D8-A-A	Aluminium	0.28	Ø15
ATFB-D8-C-B	Copper	0.90	Ø15
ATFB-D8-A-B	Aluminium	0.28	Ø15

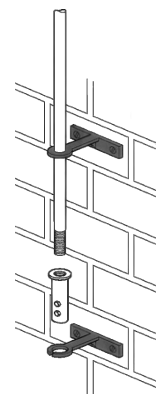

Air Terminal Rod to tape and Conductor Coupling

Air Termination System

Conforms to IEC 62561-1 and UL 96

- Made from copper or aluminium alloys.
- The rod to tape coupling is used in conjunction with the side mounting brackets to secure the air terminal rod and connect to the tape or air termination networks.

	Material	Weight (kg)	Air rod diameter (mm)	Tape Size	Conductor Size (mm ²)
ATTC-D8-C	Copper	0.23	Ø15	25x3	
ATTC-D8-A	Aluminium	0.08	Ø15	25x3	
ATCC-D8-S4-C	Copper	0.25	Ø15		50-95
ATCC-D8-S5-C	Copper	0.25	Ø15		95
ATCC-D8-S4-A	Aluminium	0.09	Ø15		50-95
ATCC-D8-S5-A	Aluminium	0.09	Ø15		95

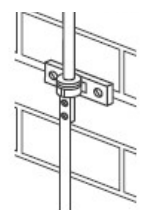



Strike Pad



Air Terminal Flat Saddle

Code

Strike Pad

Air Termination System

- Made from high-quality copper or aluminium alloys.
- Designed to provide an exposed attractive point on conductor systems hidden/embedded in the building's fabric e.g. below the tiles of a pitched roof.
- Supplied with set screw for the lightning conductor's attachment.

Applications of Strike Pads

- A Strike pad is used where it is not possible or preferred not to have a conductor on the roof or the side of a building.
- A Typical application would be on the roof of a car park where the conductor is laid into the tarmac and strike pads fitted on top, or on the side of a building where it is necessary to protect from side strikes but not possible to run conductor on the outside.

	Material	Weight (kg)
STP-C	Copper	0.41kg
STP-A	Aluminium	0.13kg

Accessories

	Material	Weight (kg)
STP-S-A	Stem Stainless steel for use with STP-A	0.07
STP-S-C	Stem Copper For use with STP-C	0.07

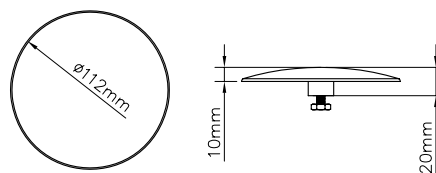

Air Terminal Flat Saddle

Air Termination System

Conforms to IEC 62561-1 and UL 96

Air Terminal Flat Saddles are made of copper alloy or aluminium. The air terminal flat saddle is fixed onto the roof network of the lightning protection system and is used in connecting the circular air termination conductors and cables to the air terminal rod.

Fixing Hardware:

- Counter sunk screw size 1-1/2" x No.10 or M6
- Plastic Wall Plug size No.10

Rod Diameter: Ø15 mm

Thread Diameter: 16 mm

- Tightening Torque 12N-m

	Conductor Size (mm ²)	Weight (kg)
ATFS-D8-S3-C	50	1.03
ATFS-D8-S4-C	70	0.95
ATFS-D8-S5-C	95	0.95

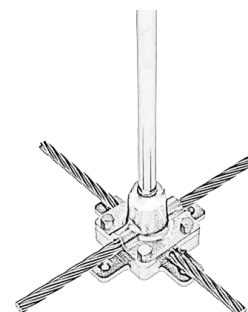



Code **Free-Standing Extendable Air Rod**
Air Termination System

SEICO provides a range of free-standing lightning interception terminals for the protection of roof-mounted or exposed equipment on surfaces where no penetration of the roof structure for anchoring is allowed. These air rods are easily constructed from a small range of components including air rods or interception pole, support frame and concrete base, to create a complete unit which when connected to the air termination network provides a highly versatile and effective lightning protection solution. The Free-Standing Air Terminal system is designed to withstand wind speeds of up to 190km/h (118mph). We recommend that all concrete bases are installed using the Protective Roof Pads.

Features:

- Protect rooftop-mounted equipment from direct lightning strikes
- Complies to IEC / BS EN 62305 Standards
- Light-Weight (kg) construction
- Corrosion Resistant
- Quick and easy to assemble
- Range of frames and concrete Weight (kg)s for different wind zones
- Large protection zones
- Modular, Versatile and robust

Manufactured from galvanized steel box section. Includes air rod and concrete blocks to create a free-standing, height adjustable air terminal. Provides an effective connection between air rod and air termination tape.
Description: Extensible tripod base and air rod

Product selection guide - Free-standing air termination

Terminal Height	<130 km/h		<150 km/h		<170 km/h		<190 km/h		
	Support	Concrete Base	Support	Concrete Base	Support	Concrete Base	Support	Concrete Base	
FSAT-H3	3.0	FSIPS-001 FSIP-SB-012x4	FSIPS-001	FSIP-SB-012x4	FSIPS-001	FSIP-SB-012x4	FSIPS-001	FSIP-SB-012x4	
FSAT-H3.5	3.5	FSIPS-001	FSIP-SB-012x4	FSIPS-001	FSIP-SB-012x4	FSIPS-001	FSIP-SB-016x4	FSIPS-001	FSIP-SB-016x4
FSAT-H4	4.0	FSIPS-001	FSIP-SB-012x4	FSIPS-001	FSIP-SB-016x4	FSIPS-001	FSIP-SB-012x8	FSIPS-001	FSIP-SB-016x8
FSAT-H4.5	4.5	FSIPT-001	FSIP-SB-016x3	FSIPT-001	FSIP-RB-020x3	FSIPT-001	FSIP-RB-025x3	FSIPT-002	FSIP-RB-012x6
FSAT-H5	5.0	FSIPT-001	FSIP-SB-016x3	FSIPT-001	FSIP-RB-020x3	FSIPT-001	FSIP-RB-025x3	FSIPT-002	FSIP-RB-012x6
FSAT-H5.5	5.5	FSIPT-001	FSIP-SB-020x3	FSIPT-001	FSIP-RB-025x3	FSIPT-002	FSIP-RB-012x6	FSIPT-002	FSIP-RB-012x6
FSAT-H6	6.0	FSIPT-002	FSIP-RB-012x6	FSIPT-002	FSIP-RB-012x6	FSIPT-002	FSIP-RB-012x6	FSIPT-002	FSIP-RB-016x6
FSAT-H6.5	6.5	FSIPT-002	FSIP-RB-012x6	FSIPT-002	FSIP-RB-012x6	FSIPT-002	FSIP-RB-012x6	FSIPT-002	FSIP-RB-025x6
FSAT-H7	7.0	FSIPT-002	FSIP-RB-012x6	FSIPT-002	FSIP-RB-016x6	FSIPT-002	FSIP-RB-020x6	*	*
FSAT-H7.5	7.5	FSIPT-002	FSIP-RB-016x6	FSIPT-002	FSIP-RB-020x6	FSIPT-002	FSIP-RB-025x6	*	*
FSAT-H8	8.0	FSIPT-002	FSIP-RB-020x6	FSIPT-002	FSIP-RB-025x6	FSIPT-003	FSIP-RB-025x10	*	*
FSAT-H9	9.0	FSIPT-003	FSIP-RB-025x10	FSIPT-003	FSIP-RB-025x10	FSIPT-003	FSIP-RB-025x10	*	*
FSAT-H10	10.0	FSIPT-002	FSIP-RB-025x10	FSIPT-002	FSIP-RB-025x10	*	*	*	*
FSAT-H11	11.0	FSIPQ-001	-	FSIPQ-001	FSIP-RB-025x17	*	*	*	*
FSAT-H12	12.0	FSIPQ-001	-	FSIPQ-001	FSIP-RB-025x17	*	*	*	*

*Please contact the SEICO Sales office for more information & advice.



Code Free-standing Interception pole

Air Termination System

These free-standing interception air rods must have sufficient height to provide a clear zone of protection around the equipment to be protected, as defined by IEC/BS EN 62305-3.

- Interception poles are manufactured from stainless steel 304 with aluminium interception tip.
- For the construction of interception air rods from 3-10m in height comprising interception pole, sports frame and concrete bases.
- Multi components, stackable system with screw retention.
- Supplied with 3 terminal lugs for base frame connection.

	Terminal Height (m)	Components	Unit Weight (kg)	Pack Quantity
FSAT-H3	3.0	Two-piece: 1.5+1.5	5.0	1
FSAT-H3.5	3.5	Two-piece: 2.0+1.5	5.5	
FSAT-H4	4.0	Two-piece: 2.5+1.5	7.0	
FSAT-H4.5	4.5	Two-piece: 3.5+1.5	9.2	
FSAT-H5	5.0	Two-piece: 3.5+1.0	10.0	
FSAT-H5.5	5.5	Two-piece: 4.0+1.5	10.6	
FSAT-H6	6.0	Three-piece: 2.0+2.0+2.0	18.0	
FSAT-H6.5	6.5	Three-piece: 2.5+2.5+2.5	21.2	
FSAT-H7	7.0	Three-piece: 3.0+2.0+2.0	23.5	
FSAT-H7.5	7.5	Three-piece: 3.5+2.0+2.0	26.0	
FSAT-H8	8.0	Three-piece: 4.0+2.0+2.0	28.7	
FSAT-H9	9.0	Three-piece: 4.0+2.5+2.5	30.5	
FSAT-H10	10.0	Three-piece: 5.0+2.5+2.5	35.5	
FSAT-H11	11.0	Three-piece: 5.0+3.5+2.5	37.8	
FSAT-H12	12.0	Three-piece: 6.0 + 3.5 + 2.5	42.9	

Free-standing Interception pole Supports

Air Termination System

SEICO provides a range of supports to suit the free-standing air terminals as shown in the above column.

Square Plate Support

For use with air terminal up to 4m. Used in conjunction with square concrete bases.

	Terminal Height (m)	Terminal Barrel Ø mm	Required mounting space mm	No. of concrete supports	Unit Weight (kg)	Pack Quantity	Material
FSIPS-001	up to 4.0m	42	650x650	4 or 8	7	1	Stainless Steel

Tripod Supports

For use with air terminals between 4.5m and 10m. Used in conjunction with round concrete bases.

	Terminal Height (m)	Terminal Barrel Ø mm	Required mounting space (mm)	No. of concrete supports	Unit Weight (kg)	Pack Quantity	Material
FSIPT-001	4.5-5.5	42	1350x1350	3	8	1	Stainless Steel
FSIPT-002	6.0-8.0	60	1850x1850	6	25	1	Stainless Steel
FSIPT-003	9.0-10.0	60	1850x1850	10	40	1	Stainless Steel

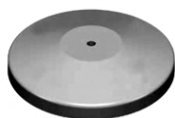
Free-Standing Interception
pole base

Code Free-standing Interception pole Supports

Quad Support

For use with air terminals between 11m and 12m. This item comes with 36 concrete bases (32 x 16kgs + 4 x 12kgs).

	Terminal Height (m)	Terminal Barrel Ø mm	Required mounting space (mm)	No. of concrete supports	Unit Weight (kg)	Pack Quantity	Material
FSIPQ-001	11.0-12.0	60	3400x3400	36	697*	1	Stainless Steel

*The unit Weight (kg) is including the concrete supports. The Weight (kg) of the base frame is 137kgs.

Free-standing Interception pole Base

Concrete Bases

Square

Used in conjunction with square plate support.

	Base Weight (kg)	Size mm	Height (m)	Pack Quantity	Material
FSIP-SB-012	12	300x300	60	1	Concrete
FSIP-SB-016	16	300x300	80	1	Concrete

Free-standing Interception pole Base

Concrete Bases

Round

Used in conjunction with the Tripod and Quad Supports. Integral M16 Thread.

	Base Weight (kg)	Ø mm	Height (mm)	Pack Quantity	Material
FSIP-RB-012	12	380	75	1	Concrete
FSIP-RB-016	16	380	93	1	Concrete
FSIP-RB-020	20	380	105	1	Concrete
FSIP-RB-025	25	420	105	1	Concrete

Free-standing Interception pole Base

Concrete Bases

Protective Roof Pad

Suits all sizes of round and square concrete bases. Protects water-proof roofing membrane from damage.

	Size mm	Pack Quantity	Material
FSIP-PRP-001	Ø 445/300x300	1	Rubber

CONDUCTORS



To keep a building from incurring lightning strike damage, it must be grounded and this is usually done with the help of electrical conductors. A down conductor system is what captures lightning current and carries it safely to the earth's dissipation network. It connects the building's metal components to the ground.

SEICO offers an extensive range of different conductors types, manufactured in both copper and aluminium. All conductors conform to British, European and world earthing and lightning protection standards. Copper can be supplied bare, tinned, PVC, LSOH and lead covered. Aluminium can be supplied bare or with PVC coating.

The selection of the conductor depends upon several criteria. The most important criteria are an environmental conditions of the installation area. For example, a conductor must withstand both corrosion and physical damage and still conduct electricity. It must also be compatible with all other connected components in the system.

Secondly, a conductor must have sufficient a cross-sectional area to be capable of carrying (without sustaining damage or deterioration) any current that may reasonably be expected.

Features:

- 1 Manufactured to withstand physical damage
- 2 Resists corrosive effects of local environment conditions
- 3 Compatible with the material of other connected components
- 4 Ease of installation
- 5 Energy efficiency
- 6 Reduction of line loss
- 7 Available in flat tape, solid circular and stranded forms
- 8 Clean finish



Copper conductor ratings:

Fault current capabilities (for one and three-second durations) for a wide selection of standard sizes of copper tapes are shown in the table below.

The following conductor ratings are based upon the recommendations of BS 7430 with an initial conductor temperature of 300C and a maximum temperature of 2500C.



BS EN 62561-2

UL-96

Copper & Aluminium Tapes:

SEICO high conductivity bare and PVC-covered copper and aluminium tapes are used for earthing and lightning protection applications. Our products are manufactured according to BS EN 13601 standards and are annealed for ease of use. We provide various PVC colours to match the most common building materials and an artistic finish to the external lightning and protection system. All our PVC coverings are UV stabilised.

Solid Circular Conductors:

SEICO solid circular conductors are made of copper, conforming to BS EN 13601 (copper) & for aluminium BS EN 755. They are used in lightning protection system networks. SEICO provides these conductors both in bare as well as PVC coverings and in five colours to match the building material and provide an aesthetic finish to external lightning protection systems. All the PVC coverings are UV stabilised and annealed for ease of use.

Cables:

SEICO conductors or cables are available in soft or annealed drawn (the copper wire that has been heat treated) and hard-drawn (the copper wire that has not been annealed after drawing). They can be used in various applications like overhead electrical transmission, distribution and grounding, and lightning protection systems where high conductivity and flexibility are required.



Bare Copper Tape



LSOH Covered Copper Tape



Green & Yellow PVC Insulated Copper Tape

Code **Bare Copper Tape**

Conforms to IEC62561-2 and UL 96

- Made of high conductivity copper tape.
- Pure copper tape is used for both lighting and earthing protection.
- All bare copper tape is sold in full coil lengths only.

Conductor Size (mm) [X x Y]	Weight (kg) Per Meter	
BCT-03-1-C	12.5 x 1.5	0.17
BCT-03-4-C	12.5 x 3	0.33
BCT-06-1-C	20 x 1.5	0.27
BCT-06-4-C	20 x 3	0.54
BCT-07-1-C	25 x 1.5	0.33
BCT-07-4-C	25 x 3	0.67
BCT-07-6-C	25 x 4	0.89
BCT-07-8-C	25 x 6	1.34
BCT-09-2-C	30 x 2	0.54
BCT-09-4-C	30 x 3	0.8
BCT-09-6-C	30 x 4	1.07
BCT-09-7-C	30 x 5	1.34
BCT-10-4-C	31 x 3	0.83
BCT-10-6-C	31.5 x 4	1.13
BCT-10-8-C	31 x 6	1.66
BCT-12-4-C	38 x 3	1.02
BCT-12-7-C	38 x 5	1.7
BCT-12-8-C	38 x 6	2.04
BCT-13-4-C	40 x 3	1.07
BCT-13-6-C	40 x 4	1.43
BCT-13-7-C	40 x 5	1.79
BCT-13-8-C	40 x 6	2.14
BCT-14-4-C	50 x 3	1.34
BCT-14-6-C	50 x 4	1.79
BCT-14-7-C	50 x 5	2.23
BCT-14-8-C	50 x 6	2.68

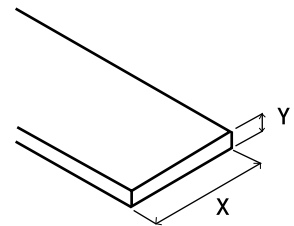

LSOH Covered Copper Tape

- All LSOH (Low Smoke Zero Halogen) covered copper tape is sold in full coil lengths only.

Conductor Size (mm) [X x Y]	Weight (kg) per Meter	Color Range	
BCTLO-07-4	25 x 3mm	0.77 kgs	•Green
BCTLO-07-8	25 x 6mm	1.53 kgs	•Green
BCTLO-14-8	50 x 6mm	2.95 kgs	•Green

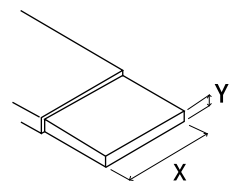

Green & Yellow PVC-Insulated Copper Tape

- High conductivity annealed copper tape
- All PVC covered copper tape is sold in full coil lengths only.

Conductor Size (mm) [X x Y]	Weight (kg) per Meter	Color Range	
BCTP-07-4-GY	25 x 3mm	0.79 kgs	•Green & •Yellow

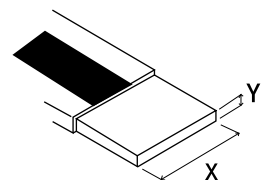



Lead Covered Copper Tape



Tinned Copper Tape



PVC Covered Copper Tape

Code **Lead Covered Copper Tape**

- All Lead covered copper tape is sold in full coil lengths only.

	Conductor Size (mm) (X x Y)	Weight (kg)
BCTL-07-4	25 x 3	2.56

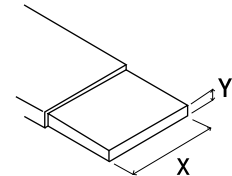

Tinned Copper Tape
Conforms to IEC 62561-2 and UL 96

- Made of high conductivity annealed tinned copper tape.
- Pure copper tape is used for both lighting and earthing protection.
- All tinned copper tape is sold in full coil lengths only.

	Conductor Size (mm) (X x Y)	Weight (kg) per Meter
BCT-03-1-T	12.5 x 1.5	0.17
BCT-06-4-T	20 x 3	0.53
BCT-07-2-T	25 x 2	0.49
BCT-07-4-T	25 x 3	0.67
BCT-07-8-T	25 x 6	1.34
BCT-09-2-T	30 x 2	0.54
BCT-10-4-T	31 x 3	0.83
BCT-12-7-T	38 x 5	1.7
BCT-13-4-T	40 x 3	1.07
BCT-13-6-T	40 x 4	1.43
BCT-14-8-T	50 x 6	2.68

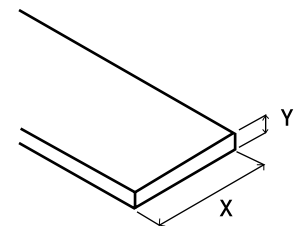

PVC Covered Copper Tape

- Made of high conductivity annealed copper tape.
- Every precaution has been taken to ensure the UV stability of PVC coverings, but as with all plastics, colour variation will occur over time.
- All tinned copper tape sold in full coil lengths only.
- Other colours and sizes are available to order.
- Different Colors are available (Black-BL, Green-GN, Gray-GY, Stone-ST, White-WT, Brown-BR) To place an order write (example -BL) after the below code to identify the colour.

	Weight (kg)	Conductor Size (X x Y)
BCTP-03-1	0.21	12.5x1.5
BCTP-07-4	0.77	25x3
BCTP-07-8	0.79	25x6
BCTP-13-8	1.53	40x6
BCTP-14-8	2.95	50x6

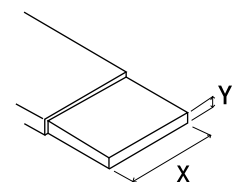



Hard Drawn Copper Tape

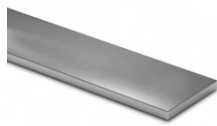

Tinned Hard Drawn Copper Tape



Anti-Vandal Down Conductor Guard

Code

Hard Drawn Copper Tape

Conductor Size (mm) (X x Y)	Weight (kg) per Meter	Approximate Length (m)	
BCTH-07-4	25 x 3	0.67	3
BCTH-07-8	25 x 6	1.34	4
BCTH-12-8	38 x 6	2.04	4
BCTH-14-8	50 x 6	2.68	3
BCTH-14-01	50 x 10	4.45	4
BCTH-15-8	75 x 6	4.00	4
BCTH-16-8	100 x 6	5.38	4

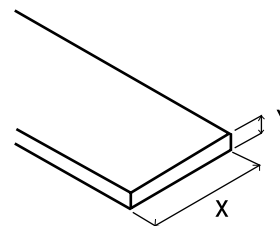

Tinned Hard Drawn Copper Tape

Conductor Size (mm) (X x Y)	Weight (kg) per Meter	Approximate Length (m)	
BCTHT-07-4	25 x 3	0.67 kgs	3
BCTHT-07-8	25 x 6	1.34 kgs	4
BCTHT-12-8	38 x 6	2.04 kgs	4
BCTHT-14-8	50 x 6	2.68 kgs	3
BCTHT-14-01	50 x 10	4.45 kgs	4
BCTHT-15-8	75 x 6	4.00 kgs	4
BCTHT-16-8	100 x 6	5.38 kgs	4

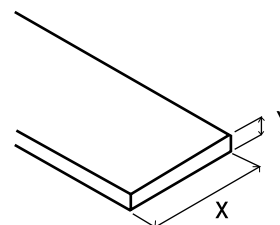

Anti-Vandal Down Conductor Guard

- Protects against vandalism and opportunity theft.
- High impact PVC, UV Stabilised to BS 1006 to reduce colour degradation.
- Suitable to protect bare 25 x 3mm flat tape, Ø8mm solid circular and 50mm² standard cable.
- Fix using No. 10 x 1 1/2" counter sunk, round head or security screws and wall plugs.

Length (mm)	Width (mm)	Height (mm)	Weight (kg) per Meter	
DCG-15L9-HDG	3000	76	16	2.90

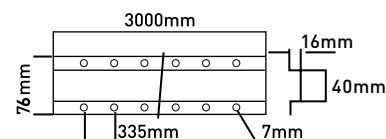



Flexible Copper Braid



Tinned Flexible Copper Braid



PVC Covered Aluminium Tape

Code

Flexible Copper Braid

- Suitable for Earth bonding.
- Supplied as standard pre-cut and drilled bonds.
- Other sizes and types (tinned) of braid can be made to order.
- Please contact us for more details.

	Conductor Size (mm)	Weight (kg) per Meter	Cross Sectional Area (mm ²)
FB-02-0-C	12 x 1	0.055	6
FB-04-1-C	15 x 1.5	0.096	10
FB-05-3-C	19 x 2.5	0.16	16
FB-07-5-C	25 x 3.5	0.34	35
FB-08-5-C	30 x 5	0.49	50
FB-09-6-C	32 x 6	0.63	70
FB-08-6-C	37 x 6	0.93	95
FB-10-6-C	45 x 6	1.15	120
FB-12-8-C	50 x 8	1.45	120

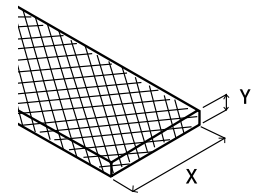

Tinned Flexible Copper Braid

	Conductor Size (mm)	Weight (kg) per Meter
FB-02-0-T	12 x 1	0.055
FB-04-1-T	15 x 1.5	0.096
FB-05-3-T	19 x 2.5	0.16
FB-07-5-T	25 x 3.5	0.34
FB-08-5-T	30 x 5	0.49
FB-09-6-T	32 x 6	0.63
FB-08-6-T	37 x 6	0.93
FB-10-6-T	45 x 6	1.15
FB-12-8-T	50 x 8	1.45

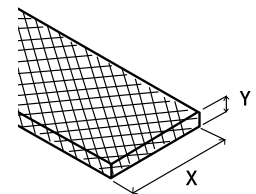

PVC Covered Aluminium Tape

Conforms to BS EN 755-5 (Aluminium) & BS 5252 (PVC Color)
*Green to BS 6746C

- Every precaution has been taken to ensure the UV stability of PVC-coverings, but as with all plastics, color variation will occur over time.
- All PVC covered aluminium copper tape is sold in full coil lengths only.
- Other colours and sizes are available to order.
- Different Colours are available (Black-BL, Green-GN, Gray-GY, Stone-ST, White-WT, Brown-BR)
To place an order write (example -BL) after the below code to identify the colour.

	Weight (kg)	Conductor Size (XxY)
BATP-03-1	0.09	12.5x1.5
BATP-06-4	0.25	20x3
BATP-07-4	0.30	25x3

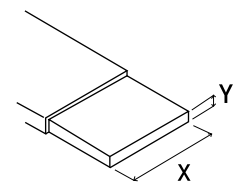



Bare Aluminium Tape



Bare Solid Circular



Bare Stranded Copper Cable



Stranded Tinned Copper Cable

Code **Bare Aluminium Tape**

• All bare aluminium tapes are sold in full coil lengths only.

Conductor Size (mm) (XxY)	Weight (kg) per Meter	Standar Coil Size (m)	
BAT-03-1	12.5 x 1.5	0.05	50
BAT-06-4	20 x 3	0.17	50
BAT-07-4	25 x 3	0.21	50
BAT-07-8	25 x 6	0.42	50
BAT-09-4	30 x 3	0.25	50
BAT-13-8	40 x 6	0.67	50
BAT-14-8	50 x 6	0.85	50

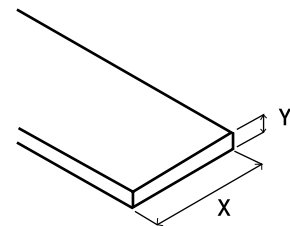

Bare Solid Circular

Conforms to IEC 62561-2 and UL 96

• All solid circular conductors sold in full coil lengths only.

Conductor Material	Cross Section Area (mm ²)	Weight (kg)	Diameter (mm)	Standard Coil size (m)	
SCI-D1-C	Copper	50.27	0.44	Ø8	50
SCI-D1-A	Aluminium	50.27	0.12	Ø8	50

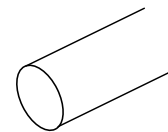

Bare Stranded Copper Cable

Conforms to BS EN 51561-2, IEC 62561-2 & UL 96

Conductor Size (mm ²)	No. of Strand / Dia.(mm)	Weight (kg) per Meter	
SCO-S14-C	6	7/1.04	0.05
SCO-S16-C	16	7/1.70	0.15
SCO-S1-C	25	7/2.14	0.23
SCO-S2-C	35	7/2.52	0.32
SCO-S3-C	50	19/1.78	0.43
SCO-S4-C	70	19/2.14	0.62
SCO-S5-C	95	19/2.52	0.86
SCO-S6-C	120	37/2.03	1.09
SCO-S7-C	150	37/2.25	1.33
SCO-S8-C	185	37/2.52	1.67
SCO-S9-C	240	61/2.25	2.20
SCO-S0-C	300	61/2.52	2.76
SCO-S17-C	400	61/2.85	3.53

Bare Stranded Tinned Copper Cable

Conforms to BS EN 51561-2, IEC 62561-2 & UL 96

Conductor Size (mm ²)	No. of Strand / Dia.(mm)	Weight (kg) per Meter	
SCO-S14-T	6	7/1.04	0.05
SCO-S16-T	16	7/1.70	0.15
SCO-S1-T	25	7/2.14	0.23
SCO-S2-T	35	7/2.52	0.32
SCO-S3-T	50	19/1.78	0.44
SCO-S4-T	70	19/2.14	0.63
SCO-S5-T	95	19/2.52	0.87
SCO-S6-T	120	37/2.03	1.10
SCO-S7-T	150	37/2.25	1.34
SCO-S8-T	185	37/2.52	1.68
SCO-S9-T	240	61/2.25	2.22
SCO-S0-T	300	61/2.52	2.78
SCO-S17-T	400	61/2.85	3.56

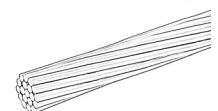



PVC Covered Solid Circular

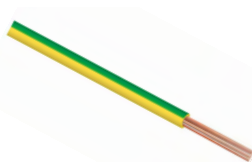

Green & Yellow PVC Insulated Stranded Copper Cable



Bimetalllic Cable

Code **PVC Covered Copper Solid Circular**

Coil Size : 50m

Cross Section Area: 50.27mm²

Material: Copper and Aluminium

- Every precaution has been taken to ensure the UV stability of PVC coverings, but as with all plastics, colour variation will occur over time.
- All PVC-covered copper solid circular sold in full coil lengths only.
- Other colors and sizes are available to order.
- Different Colours are available (Black-BL, Green-GN, Gray-GY, Stone-ST, White-WT, Brown-BR) To place an order write (example -BL) after the below code to identify the colour.

Weight (kg)

SCIP-D1-C	0.44 kgs
SCIP-D1-A	0.12 kgs

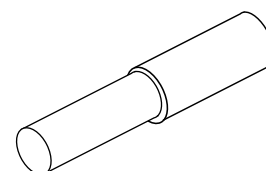

Green & Yellow PVC Insulated Straded Copper Cable

	Conductor Size (mm ²)	Stranding No. /Dia.(mm)	Weight (kg) per Meter
SCO-S16-CC	16	7/1.70	0.19
SCO-S1-CC	25	7/2.14	0.29
SCO-S2-CC	35	7/2.52	0.41
SCO-S3-CC	50	19/1.78	0.53
SCO-S4-CC	70	19/2.14	0.73
SCO-S5-CC	95	19/2.52	1.00
SCO-S6-CC	120	37/2.03	1.16
SCO-S7-CC	150	37/2.25	1.54
SCO-S8-CC	185	37/2.52	2.01
SCO-S9-CC	240	61/2.25	2.49
SCO-S0-CC	300	61/2.52	3.05
SCO-S17-CC	400	61/2.85	3.90

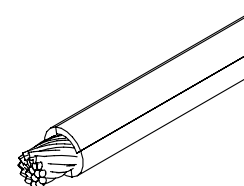

Bimetalllic Cable

	Conductor Size (AWG)	Cross sectional area (mm ²)	Nominal Diameter (mm)	Stranding No./ AWG	Weight (kg) per meter
CCSC-S14-BI	1/0	50	Ø9.96	3/5	0.41
CCSC-S16-BI	1	40	Ø8.86	3/6	0.33
CCSC-S1-BI	2	35	Ø7.90	3/7	0.26
CCSC-S2-BI	3	25	Ø7.04	3/8	0.21
CCSC-S3-BI	4	20	Ø6.27	3/9	0.16
CCSC-S4-BI	5	16	Ø5.59	3/10	0.13
CCSC-S5-BI	6	10	Ø4.42	3/12	0.08
CCSC-S6-BI	300	150	Ø15.6	7/4	1.22
CCSC-S7-BI	4/0	120	Ø13.9	7/5	0.97
CCSC-S8-BI	3/0	95	Ø12.3	7/6	0.77
CCSC-S9-BI	2/0	70	Ø11.0	7/7	0.61
CCSC-S0-BI	1/0	50	Ø9.78	7/8	0.48
CCSC-S17-BI	1	40	Ø8.71	7/9	0.38
CCSC-S18-BI	2	35	Ø7.77	7/10	0.30
CCSC-S19-BI	500	240	Ø18	19/7	1.67

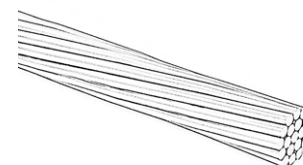



DC Tape Clip

Code

DC Tape Clip

For use with bare copper tape

Conforms to IEC / BS EN 62561-4 and UL 96

- Manufactured from high-quality alloys of either copper or aluminium for excellent corrosion resistance and high pull of loads
- Used to support and secure flat tape conductor.
- The DC Tape Clip has a hole in the base for fixing the building.
- Fix using countersunk wood screws 1 1/2" No. 10 or M6 and wall plugs.

Material: Copper

Conductor Size (mm)	Weight (kg)	
BCDTC-06-4	20x3	0.06
BCDTC-07-4	25x3	0.07
BCDTC-07-6	25x4	0.07
BCDTC-07-8	25x6	0.08
BCDTC-10-4	31x3	0.12
BCDTC-10-8	31x6	0.12
BCDTC-12-4	38x3	0.14
BCDTC-12-7	38x5	0.14
BCDTC-12-8	38x6	0.14
BCDTC-13-6	40x4	0.14
BCDTC-13-8	40x6	0.14
BCDTC-14-4	50x3	0.16
BCDTC-14-6	50x4	0.16
BCDTC-14-8	50x6	0.16

For use with PVC-covered copper tape

Conforms to IEC 62561-4 and UL 96

Material: Copper

Conductor Size (mm)	Weight (kg)	
BCDTCP-07-4	25x3	0.20
BCDTCP-07-8	25x6	0.22
BCDTCP-14-8	50x6	0.26

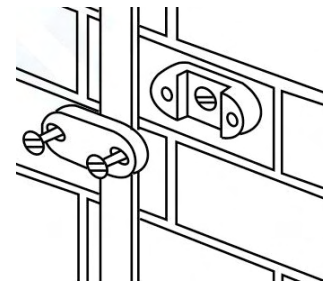

For use with bare aluminium tape

Conforms to IEC 62561-4 and UL 96

Material: Aluminium

Conductor Size (mm)	Weight (kg)	
BADTC-06-4	20x3	0.02
BADTC-07-4	25x3	0.03
BADTC-07-8	25x6	0.03
BADTC-14-8	50x6	0.05

For use with PVC-covered copper tape

Conforms to IEC 62561-4 and UL 96

Material: Aluminium

Conductor Size (mm)	Weight (kg)	
BADTCP-07-4	25x3	0.04
BADTCP-14-8	50x6	0.062

For use with Lead-covered copper tape

Material: Copper

Conductor Size (mm)	Weight (kg)	
BCDTCL-07-4	25x3	0.20



Tape Clip



One Hole Cable Clip

Code	Tape Clip		
	For use with bare copper tape		
	Conforms to IEC 62561-4 and UL 96		
	<ul style="list-style-type: none"> Manufactured from high-quality copper or aluminium, these press clips are available in a range of sizes to suit bare and PVC-covered copper and aluminium tapes. Used to support and secure flat tape conductor. 		
	Fixing Hardware:		
	<ul style="list-style-type: none"> Counter sunk screw size 1-1/2" x No.10 or M6 Plastic Wall Plug size No. 10 		
	Conductor Size (mm)	Conductor material	Weight (kg)
BCTC-06-4	20x3	Copper	0.02
BCTC-07-4	25x3	Copper	0.02

	For use with PVC-covered copper tape		
	Conforms to IEC 62561-4 and UL 96		
	Conductor Size (mm)	Conductor material	Weight (kg)
BCTP-07-4	25x3	Copper	0.02

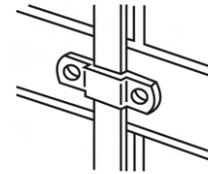

	For use with bare aluminum tape		
	Conforms to UL 96		
	Conductor Size (mm)	Conductor material	Weight (kg)
BATC-06-4	20x3	Aluminium	0.01
BATC-07-4	25x3	Aluminium	0.01
BATC-08-4	25x6	Aluminium	0.01

One Hole Cable Clip			
	Conforms to IEC 62561-4 and UL 96		
	<ul style="list-style-type: none"> Manufactured from high-quality copper or aluminium, these pressed clips are available in to suit bare and PVC covered copper and aluminium solid circular conductor, and bare copper stranded conductor. *PVC covered Ø8 & Ø10mm conductor Clip supplied in open position 		
	Fixing Hardware:		
	<ul style="list-style-type: none"> Counter sunk screw size 1-1/2" x No.10 or M6 Plastic Wall Plug size No. 10 		

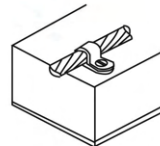

	Conductor Size (mm ²)	Conductor material	Weight (kg)
OHCC-S1-C	25	Copper	0.01
OHCC-S2-C	35	Copper	0.01
OHCC-S3-C	50	Copper	0.01
OHCC-S4-C	70	Copper	0.01
OHCC-S5-C	95	Copper	0.01
OHCC-S6-C	120	Copper	0.01
OHCC-S7-C	150	Copper	0.01
OHCC-S8-C	185	Copper	0.01
OHCC-S9-C	240	Copper	0.02
OHCC-S10-C	300	Copper	0.02

	Conductor Size (mm)	Weight (kg)	Material
OHCC-D1-C	Ø8	0.10	Copper
OHCC-D1-A	Ø8	0.10	Aluminium
OHCC-D3-C	Ø10	0.10	Copper
OHCC-D3-A	Ø10	0.10	Aluminium



Heavy Duty Cable Saddle



Glazing Bar Holdfast



Square Test Clamp

Code

Heavy Duty Cable Saddle

Conforms to IEC 62561-4 and UL 96

- Manufactured from high-quality copper and aluminium alloys for accident corrosion resistance and high pull of loads.
- Heavy duty cable saddle can be used as a support for the 10mm dia air rod or to suit PVC or Bare solid circular conductor.
- Can also be used with glazing bar holdfast and back plate holdfast stem.

Fixing Hardware:

- Counter sunk screw size 1-1/2" x No.10 or M6
- Plastic Wall Plug size No. 10

	Conductor Size (mm)	Material	Weight (kg)
HDCS-D1-C	Ø8	Copper	0.09
HDCS-D1-A	Ø8	Aluminium	0.03
HDCS-D3-C	Ø10	Copper	0.10
HDCS-D3-A	Ø10	Aluminium	0.04

- For use with stranded conductor

	Conductor Size (mm ²)	Conductor material	Weight (kg)
HDCS-S3-C	50	Copper	0.10
HDCS-S4-C	70	Copper	0.10
HDCS-S5-C	95	Copper	0.10
HDCS-S6-C	120	Copper	0.10

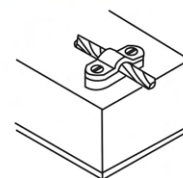

Glazing Bar Holdfast

- Manufactured from high-quality copper or aluminium alloys.
- Glazing bar holdfast has a threaded hole on the back for attaching DC tape clips into a narrow projection or extension such as angle iron.
- The Conductor clip sold separately.
- Simple to install, providing secure anchorage to thin metallic sections that cannot be drilled. e.g. Window mullions, angle iron etc.

	Conductor Material	Conductor Size (mm)	Weight (kg)
GBH-12-C	Copper	12	0.11
GBH-12-A	Aluminium	12	0.05

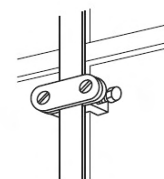

Square Test Clamp

Conforms to IEC 62561-4 and UL 96

- Made from copper alloys.
- Suitable for end to end joints and provide an overlap connection between stranded copper conductors.
- Tightening Torque 12N-m.
- Fix using counter sunk woodscrews 1 1/2" No. 10 or M6 and wall plugs

	Conductor Size (mm ²)	Material	Weight (kg)
TCC-S3-C	50	Copper	0.40
TCC-S4-C	70	Copper	0.40
TCC-S5-C	95	Copper	0.40

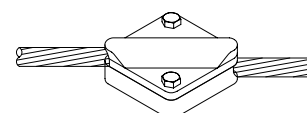



Back Plate Holdfast Stem



Slate Holdfast

Code

Back Plate Holdfast Stem

For use with bare tape

- Made from copper or aluminium alloys.
- Used to secure DC tape clip where the tape is to be attached away from the face of the wall.

Fixing Hardware:

- Counter sunk screw size 1-1/2" x No.10 or M6
- Plastic Wall Plug size No. 10

Conductor Material	Weight (kg)
Copper	0.30
Aluminium	0.10

BPHS-C

BPHS-A

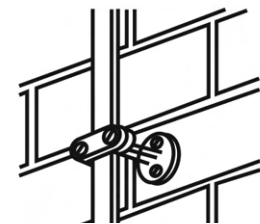

Slate Holdfast

For use with bare tape

- Designed to allow tape conductors to be fixed to tiled roofs without compromising the waterproofing nature of the roof.
- The 500mm tail fits neatly between over-lapping tiles and is wrapped around/fixed to the tile lathe for securing fitting.

Conductor Size (mm)	Color	Weight (kg)
25x3	•Brown	0.06
25x3	•Grey	0.06

SHBT-07-4-B

SHBT-07-4-G

For use with PVC covered tape

Conductor Size (mm)	Color	Weight (kg)
25x3	•Brown	0.06
25x3	•Black	0.06
25x3	•Grey	0.06
25x3	•Stone	0.06

SHPT-07-4-B

SHPT-07-4-BL

SHPT-07-4-G

SHPT-07-4-S

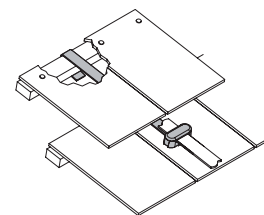

Non Metallic Slate Holdfast

For use with bare tape

- Designed to allow tape conductors to be fixed to tiled roofs without compromising the waterproofing nature of the roof.
- The 500mm tail fits neatly between over-lapping tiles and is wrapped around/fixed to the tile lathe for securing fitting.

Conductor Size (mm)	Colour	Weight (kg)
Ø8	•Brown	0.03
Ø8	•Grey	0.03

NMSH-D1-B

NMSH-D1-G

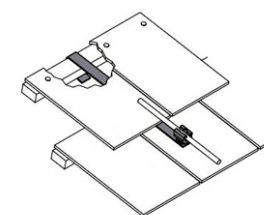



Glue down DC Tape Clip



Adhesive DC Tape Clip

Code **Glue down DC Tape Clip**

For use with bare tape

Conforms to IEC/ BS EN 62561-4 and UL 96

- Used on clay roof tiles.
- Supplied in a box of 50 complete with adhesive. An additional glue gun is required.
- Disc Ø85mm

	Conductor Size (mm)	Color	Weight (kg)
DCTC-07-4-B	25x3	•Brown	0.03
DCTC-07-4-G	25x3	•Grey	0.03

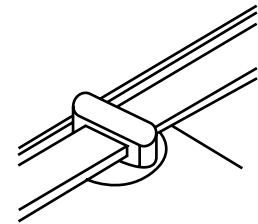

For use with PVC-covered tape

	Conductor Size (mm)	Color	Weight (kg)
PGDTC-07-4-B	25x3	•Brown	0.03
PGDTC-07-4-BL	25x3	•Black	0.03
PGDTC-07-4-GR	25x3	•Green	0.03
PGDTC-07-4-G	25x3	•Grey	0.03
PGDTC-07-4-S	25x3	•Stone	0.03
PGDTC-07-4-W	25x3	◦White	0.03

Adhesive DC Tape Clip

For use with bare tape For use with PVC-Covered tape

- Designed to secure conductors to surfaces that cannot be penetrated by a screw.
- Ideal for aluminium, spangled galvanized steel, color coated steel, glass, perspex, enamel and stainless steel etc.
- Manufactured from high-grade plastic, UV stabilized against degradation by sunlight and non-bill-tie to prevent cold weather damage.
- Use on surfaces other than PVC roofing.
- Disc Ø64mm.

	Conductor Size (mm)	Colour	Weight (kg)
ADTC-07-4-B	25x3	•Brown	0.03
ADTC-07-4-G	25x3	•Gray	0.03

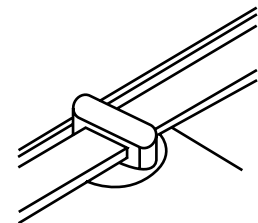

For use with PVC cover tape.

	Conductor Size (mm)	Colour	Weight (kg)
ADTCP-07-4-B	25x3	•Brown	0.03
ADTCP-07-4-BL	25x3	•Black	0.03
ADTCP-07-4-GR	25x3	•Green	0.03
ADTCP-07-4-G	25x3	•Grey	0.03
ADTCP-07-4-S	25x3	•Stone	0.03
ADTCP-07-4-W	25x3	◦White	0.03



Square Tape Clamp

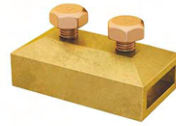

Oblong Test Clamp or Junction Clamp



Plate Type Test Clamp

Code **Square Tape Clamp**

For use with bare tape

Conforms to IEC 62561-1 and UL 96

- Manufactured from high-quality alloys of either copper or aluminium, suitable for forming straight through, cross or tee joints in continuous connection of tape.
- The Square Tape Clamp has a hole in the base for fixing the building.
- Simple to install, providing an effective low resistance connection between overlapping tapes.

Fixing Hardware:

- Counter sunk screw size 1-1/2" x No.10 or M6
- Plastic Wall Plug size No. 10
- Tightening Torque 5N-m

Conductor Size (mm)	Material	Weight (kg)
25x3	Copper	0.30
25x6	Copper	0.40
31x3	Copper	0.40
50x6	Copper	0.80
25x3	Aluminium	0.30

STC-07-4-C
STC-07-8-C
STC-10-4-C
STC-14-8-C
STC-07-4-A

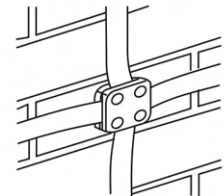

Oblong Test Clamp or Junction Clamp

Conforms to IEC 62561-1 and UL 96

- Made of copper alloy or aluminium, suitable for forming straight through the connection of tape.
- Being joints, the Oblong test clamp can also be used for disconnecting the earthing system for testing purposes.
- Tightening Torque 15N-m

Conductor Size (mm)	Material	Weight (kg)
26x8	Copper	0.29
25x3	Copper	0.29
26x8	Aluminium	0.12

OTC-08-9-C
OTC-07-4-C
OTC-08-9-A

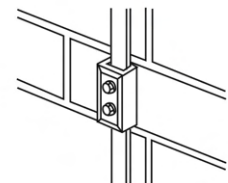

Plate Type Test Clamp

- Made of copper alloy, suitable for forming straight through, cross or tee joints of tapes.
- Used as testing points for the network to form a disconnecting joint between the down conductor system and the earthing system.

Fixing Hardware:

- Counter sunk screw size 1-1/2" x No.10 or M6
- Plastic Wall Plug size No. 10
- Tightening Torque 15N-m

Conductor Size (mm)	Weight (kg)	Material
26x8	0.62	Copper

PTTC-08-9-C

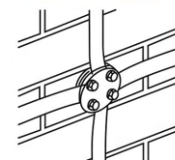



Screwdown Test Clamp



Bimetallic Connector



Push-in Plastic Cable Clip

Code

Screwdown Test Clamp

Conforms to IEC 62561-1

- Manufactured of copper alloy.
- The screw-down test clamp allows easy access to copper conductors where frequent inspection or testing may be necessary, the heavy duty lid simply screws on and off the base.
- Simple to install, providing an effective low resistance connection between overlapping tapes.

Fixing Hardware:

- Counter sunk screw size 1-1/2" x No.10 or M6
- Plastic Wall Plug size No. 10
- Tightening Torque 20N-m

Conductor Size (mm)	Weight (kg)	Material
26x8	0.84	Copper

SDTC-08-9-C

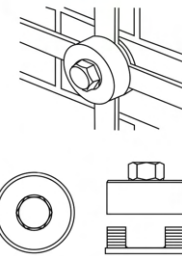

Bimetallic Connector

- Manufactured from high conductivity copper or aluminium.
- To be used for interconnecting copper and thealuminum conductors whilst avoiding bi-metallic corrosion.
- It is recommended to use oxide inhibiting compound with this connector.

Fixing Hardware:

- Counter sunk screw size 1-1/2" x No.10 or M6
- Plastic Wall Plug size No. 10
- Tightening Torque 12N-m

Conductor Size (mm)	Weight (kg)
25x3 Aluminium tape to 25x3 copper tape	0.19
Ø8mm Aluminium conductor to 25x3 copper	0.19

BIC-07-4-A

BIC-07-4-D1

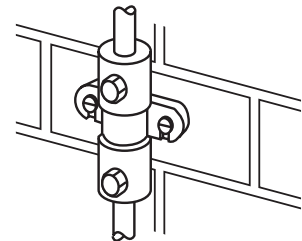

Push-in Plastic Cable Clip

- Made from polypropylene, UV stabilised against degradation by sunlight and non-brittle to prevent cold weather damage.

Fixing Hardware:

- Counter sunk screw size 1-1/2" x No.10 or M6
- Plastic Wall Plug size No. 10

Conductor Diameter (mm)	Colour
Ø8	•Grey
Ø8	•Brown
Ø10	•Black
Ø10	•Grey
Ø10	•Stone
Ø10	•White
Ø10	•Brown

PPCC-D1-G

PPCC-D1-BR

PPCC-D3-B

PPCC-D3-G

PPCC-D3-S

PPCC-D3-W

PPCC-D3-BR

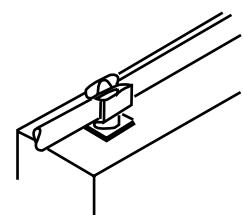



Adhesive Push-In Clip



Weldable Push-In Clip



Glue Down Push-In Clip

Code

Adhesive Push-In Clip

- Designed as a means of securing conductors to surfaces that cannot be penetrated by a screw.
- Ideal for aluminium, spangled galvanized steel, color mated steel, glass, perspex, enamel and stainless steel.
- Manufactured from high-grade plastic, UV stabilised against degradation by sunlight and non-brittle to prevent cold weather damage.

	Conductor Diameter (mm)	Colour	Weight (kg)
APCC-D1-G	Ø8	• Grey	0.02
APCC-D1-BR	Ø8	• Brown	0.02
APCC-D3-BL	Ø8	• Black	0.02
APCC-D3-G	Ø8	• Grey	0.02
APCC-D3-S	Ø8	• Stone	0.02
APCC-D3-W	Ø8	◦ White	0.02
APCC-D3-BR	Ø8	• Brown	0.02

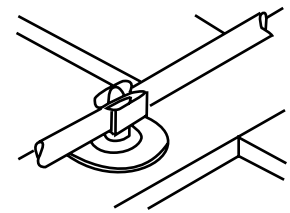

Weldable Push-In Clip

- Provides a secure means of fixing conductors to single-ply PVC roof membranes.
- Manufactured from high-grade plastic, UV stabilised against degradation by sunlight and non-brittle to prevent cold weather damage.
- Disc Ø64 mm.
- PVC covered Ø8 mm conductor.

	Conductor Size (mm)	Colour	Weight (kg)
WPCC-D1-G	Ø8	• Grey	0.03
WPCC-D1-BR	Ø8	• Brown	0.03
WPCC-D3-G	Ø10	• Gray	0.03
WPCC-D3-BR	Ø10	• Brown	0.03
WPCC-D1-S	Ø8	• Stone	0.02

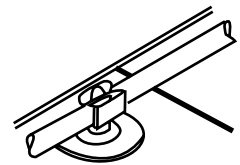

Glue Down Push-In Clip

- Used on clay roof tiles
- Supplied in a box of 50 complete with adhesive
- An Additional glue gun is required.
- Disc Ø85 mm.
- PVC covered Ø8 mm conductor.

	Conductor Size (mm)	Colour	Weight (kg)
GPCC-D1-G	Ø8	• Gray	0.03
GPCC-D1-BR	Ø8	• Brown	0.03
GPCC-D3-BL	Ø10	• Black	0.03
GPCC-D3-G	Ø10	• Gray	0.03
GPCC-D3-S	Ø10	• Stone	0.03
GPCC-D3-W	Ø10	◦ White	0.03
GPCC-D3-BR	Ø10	• Brown	0.03

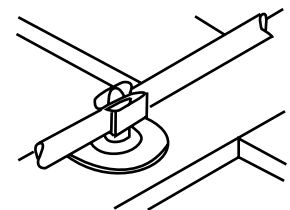



Pyramid Holdfast



Cable to cable Square Conductor Clamp

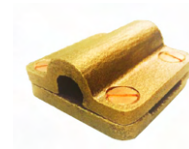

Cable To Tape Square Clamp

Code

Pyramid Holdfast

- Designed to secure bare, 8mm diameter, circular conductors to flat roofs.
- Supplied and filled with concrete, the conductor is held in place by the Weight (kg) of the holdfast.
- The lip around the base of the product permits the holdfast to be built into bitumen-type roofs.

Conductor Size (mm)	Weight (kg)
Ø8	0.97

PH-D1

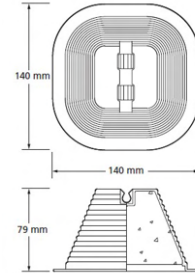

Square Conductor Clamp

Conforms to IEC 62561-1 and UL 96

- Made from copper alloys.
- The Square conductor clamp is used for straight through, tee and cross joints in a stranded copper conductor.
- Tightening Torque 5N-m

Conductor Size (mm ²)	Material	Weight (kg)
SCC-S3-C	Copper	0.32
SCC-S4-C	Copper	0.29
SCC-S5-C	Copper	0.25
SCC-S9-C	Copper	0.35
SSC-D1-C	Copper	0.17
SCC-D1-A	Aluminium	0.07

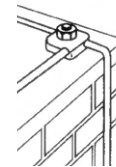

Cable To Tape Square Clamp

- Manufactured from copper alloys.
- Suitable for connection between Conductor Tap (mm²) and stranded copper conductor.
- Simple to install, providing an effective low resistance connection between Conductor Tap (mm²) and stranded copper conductor, allowing cross, tee, throughout and right angle joints to be formed.

Fixing Hardware:

- Counter sunk screw size 1-1/2" x No.10 or M6
- Plastic Wall Plug size No. 10
- Tightening Torque 5N-m

Conductor Size	Weight (kg)	Conductor Material	
CTSC-S3-07-4-C	25x3mm & 50mm ²	0.32	Copper
CTSC-S4-07-4-C	25x3mm & 70mm ²	0.30	Copper
CTSC-S5-07-4-C	25x3mm & 95mm ²	0.28	Copper

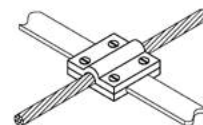



Tee Clamp



Jointing Parallel Clamp



Test Clamp

Code

Tee Clamp

Conforms to IEC 62561-1 and UL 96

- Made from copper and aluminium alloys.
- Used for forming tee joints in a solid circular conductor.
- Tightening Torque 12N-m

	Material	Weight (kg)	Conductor Size (mm)
TJSC-D1-C	Copper	0.17	Ø8
TJSC-D1-A	Aluminium	0.07	Ø8

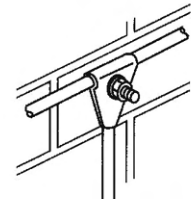

Jointing Parallel Clamp

Conforms to IEC 62561-1 and UL 96

- Made from copper and aluminium alloys.
- Used for forming straight through and parallel joints in a solid circular conductor.
- Tightening Torque 12N-m

	Material	Weight (kg)	Conductor Size (mm)
JPC-D1-C	Copper	0.17	Ø8
JPC-D1-A	Aluminium	0.08	Ø8

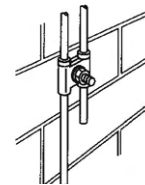

Test Clamp

Conforms to IEC 62561-1 and UL 96

- Made from copper and aluminium alloys.
- Used for forming straight or tee joints in solid circular conductor and used for disconnection and test purposes.
- Test clamp can produce circular to tape connection in both through and tee configurations.
- Tightening Torque 12Nm.

	Material	Conductor Size (mm)	Conductor Diameter	Weight (kg)
TSC-D1-C	Copper	25x3	Ø8	0.20
TSC-D1-A	Aluminium	25x3	Ø8	0.09

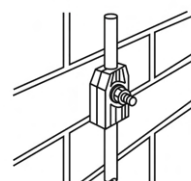



Countersunk Wood Screws



Round Head Wood Screws



Plastic Wall Plugs



Masonry Drills



Round Head Copper Nails



Countersunk Set Screws



Round Head Rivets



Hexagonal head set Screws



Plain Washers

Code	Countersunk Wood Screws		
	Size	Material	Weight (kg) Per 100
HW46-10-D39-ZN	1-1/2" x #10	Zinc Plated Steel	0.50
HW46-12-D39-ZN	1-1/2" x #12	Zinc Plated Steel	0.60
HW46-10-D39-B	1-1/2" x #10	Brass	0.50
HW46-12-D39-B	1-1/2" x #12	Brass	0.60

Code	Countersunk Set Screws	
	Size	Weight (kg)
WNAIL-50	50mm long	0.70

Round Head Rivets			
Size (mm)	Material	Weight (kg)	
HW50-05-12-A	5 x 12	Aluminium	0.12
HW50-05-20-A	5 x 20	Aluminium	0.15
HW50-05-12-C	5 x 12	Copper	0.35
HW50-05-20-C	5 x 20	Copper	0.45

Round Head Wood Screws		
Weight (kg) Per 100: 0.50kg		
	Size	Material
RHWS-10-D39-ZN	1-1/2" x #10	Zinc Plated Steel
RHWS-10-D39-B	1-1/2" x #10	Brass

Hexagonal head set Screws			
	Size (mm)	Material	Weight (kg) per 100
HW01-10-25-PB	M10 x 25	Phosphor Bronze	2.85
HW01-10-35-PB	M10 x 35	Phosphor Bronze	3.40
HW01-12-25-PB	M12 x 25	Phosphor Bronze	4.50
HW01-12-35-PB	M12 x 35	Phosphor Bronze	5.00
HW01-08-16-B	M8 x 16	Brass	1.75
HW01-10-25-B	M10 x 25	Brass	2.50
HW01-10-35-B	M10 x 35	Brass	3.20
HW01-12-25-B	M12 x 25	Brass	3.80
HW01-12-35-B	M12 x 35	Brass	4.70

Plastic Wall Plugs		
Weight (kg): 0.06		
	Size	Colour
HW46A-10	#10	Red
HW46A-12	#12	Brown

Masonry Drills		
Weight (kg): 0.02		
Material: HSS		
	Size	
DB-10-12	#10	
DB-12-12	#12	

Plain Washers			
	Size (mm)	Material	Weight (kg) per 100
HW07-06-PB	6	Phosphor Bronze	0.05
HW07-10-PB	10	Phosphor Bronze	0.25
HW07-12-PB	12	Phosphor Bronze	0.50
HW07-06-B	6	Brass	0.05
HW07-08-B	8	Brass	0.15
HW07-10-B	10	Brass	0.25
HW07-12-B	12	Brass	0.50

Round Head Copper Nails		
	Size	Weight (kg)
WNAIL-2	50mm long	0.70



Washers Lock



Hexagonal Nut

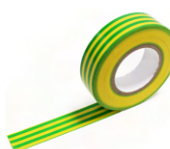

Insulating Tape



Denso Tape



Silfos



Flux



Tinmans Solder



Oxide Inhibiting Compound

Code	Washers Lock		
	Size (mm)	Material	Weight (kg) per 100
HW07A-06-PB	M6	Phosphor Bronze	0.04
HW07A-10-PB	M10	Phosphor Bronze	0.20
HW07A-12-PB	M12	Phosphor Bronze	0.20

Code	Silfos	
	Size	Weight (kg) Per 100
SILFOS-50-8	0.12mm x 50mm x 8M long	0.50

Hexagonal Nut			
	Size (mm)	Material	Weight (kg) per 100
HW05-10-PB	M10	Phosphor Bronze	1.25
HW05-12-PB	M12	Phosphor Bronze	1.80
HW05-06-B	M6	Brass	0.25
HW05-08-B	M8	Brass	0.80
HW05-10-B	M10	Brass	1.15
HW05-12-B	M12	Brass	1.65

Flux	
	Weight (kg)
FLUX-EL	0.08

Insulating Tape		
Green/Yellow general purpose insulating tape		
	Size	Weight (kg) Per 100
PC-25-33	25mm x 33M long	0.14

Tinmans Solder		
An alloy of silver, phosphorous and copper. Used to braze copper in the air without the use of flux CoSHH datasheet available on request.		
	Size	Weight (kg)
TINMANS	60% Tin, 40% Lead	0.26

Denso Tape		
A waterproof for wrapping underground joints. COSH H Datasheet available on request		
	Size	Weight (kg) Per 100
DT	50mm x 10M long	0.76

Oxide Inhibiting Compound		
Recommended for use on aluminium fittings and aluminium to copper connections, on all bare conductors and bus bars. This assures a high conductivity joint by sealing out air and moisture to prevent corrosion and reformation of an oxide film.		
	Description	Weight (kg)
OIC-8	Boz plastic container	0.23

EARTHING PROTECTION SYSTEM

After decades of work, Seico design engineers have come up with an effective and efficient earthing system which ensures the protection of personnel and equipment from the danger associated with fault currents. The earth termination network is the means through which the current is dissipated into the earth.

Earthing systems typically fall into (but are not limited to) one of the following categories:

- Power generation, transmission and distribution
- Oil and Gas sectors
- Lightning protection
- Control of undesirable static electricity
- Telecommunications.

Earthing System Design Considerations

To create an effective earthing system, a low electrical resistance to earth connection must be achieved, using high quality conductors with sufficient cross-sectional area to

carry the expected current flow. The conductors must also have high resistance to corrosion and meet internationally recognised European and British earthing standards

Additional factors to consider when designing an earthing system:

1. Soil Resistivity surveys to determine ground resistivity.
2. Soil moisture contents - more moisture reduces soil resistance.
3. Chemical composition of the soil - certain salts and minerals affect soil resistivity.
4. Temperature - if the ground is frozen its resistance is much higher.
5. The extent of any buried services could affect the earth termination network.
6. Details of metallic service pipes, rails, tanks, etc., may need grounding to the earthing system to prevent the danger of side flashing.
7. Area (available) for installing earth electrodes.

Features:

- 1 Low electrical resistance to earth
- 2 Excellent corrosion resistance
- 3 Ability to carry the required current repeatedly
- 4 Reliability lifespan of at least 30 years

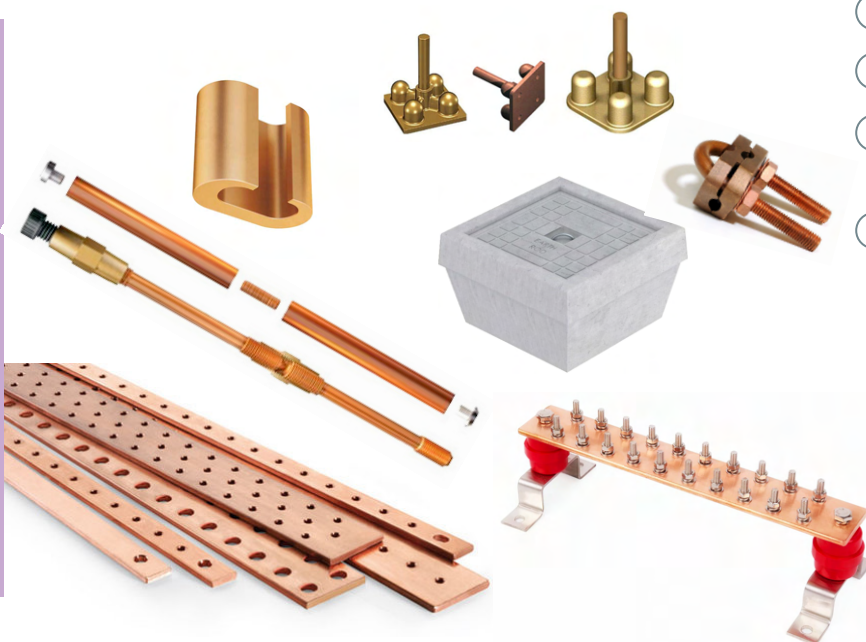

Our Earthing products include all materials and methods of connection necessary for an effective earthing system, including:

- Earth rods and plates,
- Mechanical clamps,
- Earth inspection pits
- Compression connectors
- Earth Bars
- Conductors
- Earth Electrode backfills
- SEICOWELD Exothermic Welding



BS EN 62561-1, BS EN 62561-2
UL-467 & UL-486 A-B

Earth Rod with Accessories:

SEICO earth rods offer installers the most economical method of achieving low earth resistance. Each rod has high tensile strength and a low carbon steel core. 99.95% pure copper is applied electrolytically and forms a metallurgical bond between the steel core and the copper. This combination makes the rod ideal for deep driving and also provides lasting resistance to corrosion. The threads are formed by a cold rolling process which ensures strength and maintains the molecularly bonded copper covering along the full length of the threads. Cold-rolled threads are stronger than cut threads. The standard copper thickness is 0.25mm. Greater copper thicknesses are also available.

SEICO offers earth rods in different types:

- Copper bond Earth Rods
- Galvanised Steel Earth Rod Set
- Stainless Steel Earth Rods
- Solid Copper Earth Rods

SEICO provides the following accessories for the earth rods;

- Driving Stud
- Threaded Coupling
- Spike

Earthing Protection System Clamps:

SEICO provides a high copper content alloy earth rod clamp for connecting the earthing conductor to the earth rod. These clamps ensure good electrical contact and resist corrosion throughout the lifetime of the installation. We also provide a wide range of "U" bolt clamps that can be used to connect flat tapes and stranded cables to earth rods, reinforcing bars (re-bar), hand rails, etc.

The versatile range of Seico re-bar clamps are used to connect re-bar to re-bar or re-bar to stranded cable. They provide a tight mechanical connection along with excellent corrosion resistance.

SEICO Tower earth clamps are used for bonding copper conductors to steel surfaces.

The double-plate design provides a robust splice in areas where cladding may be installed or where the entire clamp will be covered by concrete. The clamp is fixed by drilling a hole in the steelwork and securing it with the set screw provided.

SEICO Parallel Groove Clamps for stranded copper cable connections are manufactured from high-strength, corrosion-resistant copper alloy and assembled with two stainless steel set screws.

Earth Inspection Pits:

SEICO Earth inspection pits are used to protect earth electrode connections. High-strength pits are available in plastic and concrete. Our concrete earth inspection pits are load rated to 4,500 kilograms and are suitable for most industrial applications. The housing can have an internal earth bar fitted diagonally across in slots provided in the base.

SEICO light duty earth inspection pits have a maximum safe working load of 2,000 kilograms. They are UV stabilised against sunlight degradation and non-brittle to prevent cold weather damage.

SEICO heavy-duty earth pits are designed, shaped and sized to easily fit into brick paved walkways. The lip of the base makes a flush fit with standard-sized bricks making the pit blend in without the need for a cement encasement. These pits will withstand loads of up to 6,000 kilograms and are suitable for most commercial and industrial applications.

Flexible Copper Earth Braids:

Our flexible copper braid bonds are used for bonding metal gates, doors, fences, etc

Earth Points:

SEICO earth bonding points are installed to provide a convenient earth system connection point in concrete structures. When cast into concrete, they connect the re-bar to the earthing or lightning protection system.

Earth Bars:

SEICO earth bars are an efficient and convenient way of creating a common earth point. Integral disconnecting links mean the earth bars can be isolated for testing process.

Earthing Compound:

SEICO earthing compounds are used to create effective earth resistance. They are an electrically conductive aggregate. A block of conductive concrete is formed when this mixes with cement. When combined with cement and water, it forms permanent, electrically conductive concrete. The conductive concrete is ideal for use in difficult grounding conditions. It is a permanent, stable and maintenance-free solution for obtaining low resistivity earth. The typical mixing ratio of low-resistance earthing compound to cement is 2:1 by Weight (kg).

Compression Lugs:

SEICO compression connectors are designed to crimp onto the end of wires. One hole allows connection to another lug with a bolt. They are manufactured from high-conductivity seamless copper tubing and feature bell mouth entry for cables. All terminals are annealed (to avoid cracking and splitting when crimped) and electro-tin plated to combine maximum electrical conductivity with mechanical strength.

C – Crimps:

SEICO C-Crimp copper connectors are designed specifically for tap and parallel connections of stranded copper cables in low voltage earthing applications.



Copper Bond Threaded Earth Rod



Earth Rod Copper Bond Driving Stud



Earth Rod Threaded Coupling

Code

Copper Bond Threaded Earth Rod

Conforms to IEC 62561-2 and UL 467

- Made of molecularly 99.9% pure electrolytic copper into a low carbon steel core.
- Mostly used due to strength, corrosion resistance and economical method of achieving low earth resistance.
- The minimum copper thickness is 250 microns.
- High tensile low carbon steel core with a minimum of 250 microns of copper.
- All earth rod sizes with an overall <8ft length will be in kits with coupler and driving stud to meet the minimum length of 8ft.

Material: Steel Copper Bond

	Rod Length (mm)	Nominal Diameter (")	Standard Overall Diameter (mm)	Weight (kg)
ERT-L4-D32-CB	1200	Ø1/2	Ø12.7	1.18
ERT-L5-D32-CB	1500	Ø1/2	Ø12.7	1.55
ERT-L6-D32-CB	1800	Ø1/2	Ø12.7	1.76
ERT-L8-D32-CB	2400	Ø1/2	Ø12.7	2.38
ERT-L4-D33-CB	1200	Ø5/8	Ø14.2	1.53
ERT-L5-D33-CB	1500	Ø5/8	Ø14.2	1.88
ERT-L6-D33-CB	1800	Ø5/8	Ø14.2	2.29
ERT-L8-D33-CB	2400	Ø5/8	Ø14.2	3.00
ERT-L9-D33-CB	3000	Ø5/8	Ø14.2	3.79
ERT-L4-D34-CB	1200	Ø3/4	Ø17.2	2.19
ERT-L5-D34-CB	1500	Ø3/4	Ø17.2	2.73
ERT-L6-D34-CB	1800	Ø3/4	Ø17.2	3.27
ERT-L8-D34-CB	2400	Ø3/4	Ø17.2	4.35
ERT-L9-D34-CB	3000	Ø3/4	Ø17.2	5.44
ERT-L9-D19-CB	3000	Ø3/4	Ø19	7.5
ERT-L9-D35-CB	3000	1	Ø25	12

Earth Rod Copper Bond Driving Stud

Conforms to IEC 62561-2

- Made of Black Hardened Steel.
- Driving stud are suitable for driving earth rods by hand or with power tools.

	Rod Diameter (")	Weight (kg)
ERCBDS-D32-BH	1/2	0.05
ERCBDS-D33-BH	5/8	0.08
ERCBDS-D34-BH	3/4	0.12

Earth Rod Threaded Coupling

Conforms to IEC 62561-2 and UL 467

- Made from high-quality copper alloy.
- It joins the lengths of earth rods together & facilitates deep driving and ensure continual contact between rods, during & after driving.

	Rod Diameter (")	Material	Weight (kg)
ERCT-D32-C	1/2	Copper	0.09
ERCT-D33-C	5/8	Copper	0.08
ERCT-D34-C	3/4	Copper	0.13

Earth Rod Solid Driving Stud

Conforms to IEC 62561-2 and UL 467

- Made of Black Hardened Steel.
- Driving studs are suitable for driving earth rods by hand or with a power hammer.

	Rod Diameter (mm)	Weight (kg)
ERSDS-08-BH	15	0.02
ERSDS-012-BH	20	0.05



Copper Bond Unthreaded Earth Rod



Earth Rod Unthreaded Coupling



Solid Copper And Stainless Steel Threaded Earth Rod

CODE
ERU-L4-D2-CB
ERU-L4-D4-CB
ERU-L5-D4-CB
ERU-L6-D4-CB
ERU-LB-D4-CB
ERU-L4-D6-CB
ERU-L5-D6-CB
ERU-L6-D6-CB
ERU-L8-D6-CB
ERU-L9-D10-CB
ERU-L4-D10-CB
ERU-L5-D10-CB
ERU-L6-D10-CB
ERU-L8-D10-CB

Copper Bond Unthreaded Earth Rod

Conforms to IEC 62561-2 and UL 467

- Made of molecularly 99.9% pure electrolytic copper onto a low carbon steel core.
- These rods have no threads and are joined together by using a taper fit coupling.
- The rods can be deep driven with power hammers or placed in a borehole backfilled with Marconite or Bentonite.
- All earth rod sizes with an overall <8ft length will be in kits with coupler and driving stud to meet the minimum length of 8ft.

• Material: Copper Bond

Rod Length (mm)	Nominal Diameter (mm)	Weight (kg)
1200	9	1.18
1200	12.7	1.55
1500	12.7	1.76
1800	12.7	2.38
2400	12.7	1.53
1200	14.2	1.88
1500	14.2	2.29
1800	14.2	3.00
2400	14.2	3.79
3000	14.2	2.19
1200	17.2	2.73
1500	17.2	3.27
1800	17.2	4.35
2400	17.2	5.44

ERCU-D4
ERCU-D6
ERCU-D10

Earth Rod Unthreaded Coupling

- Made from high-quality copper alloy.
- It joins the lengths of unthreaded copper bond earth rods together so that rods can be deep driven and ensure continual contact through the coupling.

Rod Diameter (mm)	Material	Weight (kg)
12.7	Copper	0.09
14.2	Copper	0.08
17.2	Copper	0.13

ERT-L4-D8-C
ERT-L5-D8-C
ERT-L9-D8-C
ERT-L4-D12-C
ERT-L5-D12-C
ERT-L9-D12-C
ERT-L4-D9-SS
ERT-L5-D9-SS
ERT-L9-D9-SS
ERT-L5-D12-SS
ERT-L9-D12-SS

Solid Copper and Stainless steel threaded earth rod

Conforms to IEC 62561-2

- Made of pure copper or stainless steel (two grades are available SS316 & SS304L).
- Designed for use in extreme high corrosion resistance (eg. near sea)
- All earth rod sizes with an overall <8ft length will be in kits with coupler and driving stud to meet the minimum length of 8ft.

Length (mm)	Diameter (mm)	Material	Weight (kg)
1200	Ø15	Solid Copper	1.88
1500	Ø15	Solid Copper	3.34
3000	Ø15	Solid Copper	4.70
1200	Ø20	Solid Copper	3.34
1500	Ø20	Solid Copper	4.18
3000	Ø20	Solid Copper	8.36
1200	Ø16	Stainless Steel	1.87
1500	Ø16	Stainless Steel	2.34
3000	Ø16	Stainless Steel	4.68
1500	Ø20	Stainless Steel	3.65
3000	Ø20	Stainless Steel	7.30



Earth Rod Dowel Coupling



Earth Rod Spike



Lightweight (kg) Inspection Pit

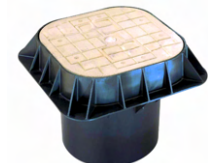

Lightweight (kg) Inspection Pit with Concrete Lid

Code	Earth Rod Dowel Coupling		
	<ul style="list-style-type: none"> Made from stainless steel. It joins the length of solid copper and stainless steel earth rod. 		
	Rod Diameter (mm)	Material	Weight (kg)
ERSSDC-D8-SS316	Ø15	Stainless Steel	0.02
ERSSDC-D10-SS316	Ø17.2	Stainless Steel	0.02
ERSSDC-D12-SS316	Ø20	Stainless Steel	0.02

Code	Earth Rod Spike		
	<ul style="list-style-type: none"> Made from stainless steel. Spike enables the rod to be driven easily and prevents damage to the copper rod. 		
	Rod Diameter (mm)	Material	Weight (kg)
ERS-D8-SS316	Ø15	Stainless Steel	0.02
ERS-D12-SS316	Ø20	Stainless Steel	0.02
ERS-D8-SS304	Ø15	Stainless Steel	0.02
ERS-D12-SS304	Ø20	Stainless Steel	0.02

Code	Lightweight Inspection Pit		
	<ul style="list-style-type: none"> Made of polymer, is UV stable and chemically resistant. The lightweight (kg) inspection pit has a lockable lid and an improved working area. The lightweight (kg) inspection pit with polymer lid is load rated to 5000 kg and is suitable for general heavy-duty use. 		
	Description	Load Rating (kg)	Weight (kg)
LIP-G	Lightweight (kg) inspection pit with gray lid	5000	1.80
LIP-B	Lightweight (kg) inspection pit with black lid	5000	1.80

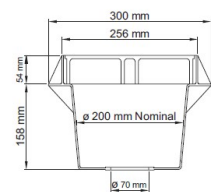

Code	LightWeight (kg) Inspection Pit with Concrete Lid	
	<ul style="list-style-type: none"> Made of polymer is UV stable and chemically resistant with a concrete lid. Suitable for use in pedestrianised and light vehicular areas. The lightweight (kg) inspection pit with the concrete pit is load rated at 1200 kg. 	
	Description	Weight (kg)
LIP-C	Lightweight (kg) inspection pit with concrete lid	7.50kg

Code	Earth Bar and Accessories for Light Weight (kg) instruction pit	
	<ul style="list-style-type: none"> Made of polymer is UV stable and chemically resistant with a concrete lid. Suitable for use in pedestrianised and light vehicular areas. The lightweight (kg) inspection pit with the concrete pit is load rated at 1200 kg. 	
	Description	Weight (kg)
EB-5H-LIP	5 hole earth bar	0.40
JB-M8100	M8x100MM mild steel J-bottlifting hook	0.04
AL-M860SS	M8x60MM stainless steel allen caphead screw (2/lid)	0.03

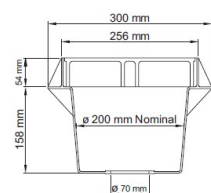



Solid Copper Earth Plate

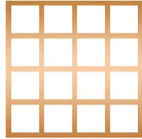

Lattice Copper Earth Plate



Concrete Inspection Pit



CIP Earth Bar

Code
SEP-600-600-1.5
SEP-900-900-1.5
SEP-600-600-3
SEP-900-900-3

Solid Copper Earth Plate

Conforms to **UL 467** and **BS EN 62561-2**

Material: Copper

- Made of pure copper.
- Solid copper earth plates are used as part of an earthing network.
- They provide a long-lasting solution where earth rods are unsuitable.

Size (mm)	Weight (kg)
600x600x1.5	5.00
900x900x1.5	11.21
600x600x3.0	9.74
900x900x3.0	21.74

LEP-600-600-3
LEP-900-900-3

Lattice Copper Earth Plate

Conforms to **IEC62561-2** and **UL 467**

- Made of pure copper.
- Lattice copper earth plate is preferred on some telecoms towers where step potential could cause problems.
- With the use of bentonite provides a long-lasting earth.

Size	Material	Weight (kg)
600x600x3.0mm	Copper	3.98
900x900x3.0mm	Copper	7.20

CIP

Concrete Inspection Pit

Conforms to **IEC 62561-5**

- Made of Concrete.
- The concrete inspection pit is load rated to 4500 kg, suitable for most types of earthing and lightning protection installations.
- The concrete inspection pit can have a copper earth bar fitted diagonally across its slot, to provide multiple connections.

Description	Weight (kg)
Concrete Inspection Pit	26kg

EB-5H
EB-7H

ACCESSORIES

Description	Material	Weight (kg)
5 hole earth bar	Copper	0.21
7 hole earth bar	Copper	0.21

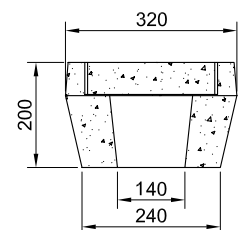



Earth Rod Seal



Bentonite- Earthing Compound



SEICO CEM Earthing Compound

Code
EROS-S
EROS-D

Earth Rod Seal

The SEICO market leading range of earth rod seals are simply the best available in the industry offering four variations with very low components, extremely robust and simple to install. Earth rod seals are usually installed in the basement or underground car park which requires the earth rod to pass through the building blinding slab and water proof membrane.

- For use with 5/8" UNC rods only and with lightweight (kg) inspection pit.
- A waterproof earth electrode seal for use in constructions where internal earth are specified.

SEICO seals offer superior features and benefits:

- Simple to install, very easy to align, no concern with damage O rings and leaks.
- Extremely robust, making damage during installation very unlikely.
- Very few components, a single flange seal have only two components - reducing the risk of lost parts.
- Very adaptable SEICO seals give the designer/installer the convenience of being able to use with.

- 1) Heavy-duty plastic inspection pits
- 2) Concrete inspection pit
- 3) No inspection pit at all

Description	Weight (kg)
Single-flange earth rod seal (for most applications)	2.00
Double Flange earth rod seal (for deep concrete slab)	3.20

BENTONIT-P-25
BENTONIT-GR-25

Bentonite- Earthing Compound

Bentonite can be supplied In powder or granular form and it is a moisture-retaining clay which Is used to reduce soil resistivity.

Powder

The preferred method for pouring into boreholes is to ensure the mixture is thin enough consistency to reach the bottom of the borehole, If diamond drilling is required for deep holes 40 meters and deeper and the Bentonite Is to be pumped through the core Into the hole powder would be the preferred option.

Granular

Its easier to handle in granular form, the powder can cause dust in windy conditions and blow away, granular Is the preferred option for filling trenches where the conductor Is covered with Bentonite and then water pared over and robed in the trench.

Description	Weight (kg)
Bentonite Powder	25
Bentonite Granular	25

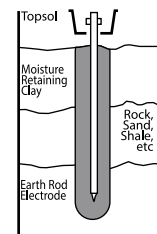

MARCON-25KG

SEICO-CEM Earthing Compound

Marconite forms a permanent solution when mixed with cement and, when certain ground conditions make it difficult to obtain reliable earth resistance or installations might require a low resistance. Marconite Is used as a backfill for earth rods and plates.

Description	Weight (kg)
Marconite	25



Earth Rod To Tape Clamp



Earth Rod To Cable Clamp

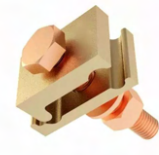

Tower Earth Clamps

Code **Earth Rod To Tape Clamp (Type A)**

Conforms to IEC 62561-1 and UL 467

- Made of copper alloy, used for joining earth rods to copper tapes, these are available to suit different sizes of rods and tapes.
- Tightening Torque 15Nm

Material: Copper

	Rod Size (")	Conductor Size (mm ²)	Weight (kg)
ERTC-D32-08-02	1/2	26x12	0.15
ERTC-D33-08-02	5/8	26x12	0.15
ERTC-D34-08-01	3/4	26x10	0.15
ERTC-D33-09-02	5/8	30x2	0.16
ERTC-D34-09-02	3/4	30x2	0.16
ERTC-D33-13-02	5/8	40x12	0.24
ERTC-D33-14-09	5/8	50x8	0.30
ERTC-D34-14-02	3/4	50x12	0.30
ERTC-D32-08-06	1/2	26x20	0.23
ERTC-D33-08-05	5/8	26x19	0.23
ERTC-D34-08-01	3/4	26x10	0.23
ERTC-D35-08-01	1	26x10	0.23

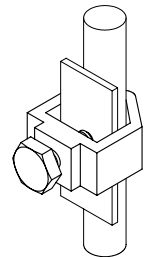

Earth Rod To Cable Clamp (Type G)

Conforms to IEC 62561-1 and UL 467

- Made of copper alloy, used for joining earth rods to copper cables, these are available to suit different sizes of rods and cables.
- Tightening Torque 15N-m

Material: Copper

	Rod Size (")	Conductor Size (mm ²)	Weight (kg)
ERCC-D31-S2	3/8	35	0.03
ERCC-D32-S3	1/2	50	0.05
ERCC-D33-S4	5/8	70	0.06
ERCC-D34-S5	3/4	95	0.06
ERCC-D35-S6	1	120	0.14

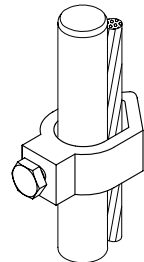

Tower Earth Clamps

- Made of copper or aluminium alloy, used for bonding copper cable or wire to steel structures.
- Tightening Torque 12N-m

	Conductor Size (mm ²)	Material	Weight (kg)
TEC-S3-C	50	Copper	0.10
TEC-S4-C	70	Copper	0.15
TEC-S6-C	120	Copper	0.22
TEC-S8-C	185	Copper	0.30
TEC-S9-C	240	Copper	0.40
TEC-S3-A	50	Aluminium	0.05

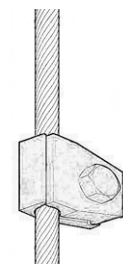



Earth Rod U-Bolt Clamp



Earth Rod To Cable GU Type Clamp



Earth Rod To Cable Lug Clamp

Code
ERUC-D33
ERUC-D34
ERUC-D35
ERUC-D36
ERUC-D37

Earth Rod U-Bolt Clamp

Conforms to IEC 62561-1 and UL 467

- Made of copper alloy, used for clamping and connecting tape to the earth rod.
- They provide a low resistance connection between flat tape or stranded conductor and the earth rod or re-bar.
- U-Bolt threaded with M10 size.

Rod Diameter (")	Material	Weight (kg)
Ø 5/8	Copper	0.20
Ø 3/4	Copper	0.20
Ø 1	Copper	0.20
Ø 1 1/2	Copper	0.37
Ø 2	Copper	0.44

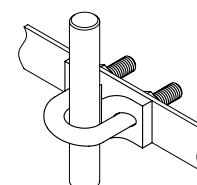

ERGC-D33-S5
ERGC-D34-S4
ERGC-D33-S8
ERGC-D34-S7
ERGC-D33-S0
ERGC-D34-S0
ERGC-D35-S4
ERGC-D35-S7
ERGC-D35-S0

Earth Rod To Cable GU Type Clamp

Conforms to IEC 62561-1 and UL 467

- Made of copper alloy, used for clamping and connecting cable to the earth rod.
- Tightening Torque 12N-m.
- They provide a low resistance connection between solid circular or stranded conductors and earth rods or re-bar.

Rod Diameter (")	Conductor Range (mm ²)	Weight (kg)	Material
Ø 5/8	16-95	0.39	Copper
Ø 3/4	16-70	0.39	Copper
Ø 5/8	70-185	0.39	Copper
Ø 3/4	70-150	0.39	Copper
Ø 5/8	150-300	0.62	Copper
Ø 3/4	150-300	0.62	Copper
Ø 1	16-70	0.39	Copper
Ø 1	70-150	0.39	Copper
Ø 1	150-300	0.62	Copper

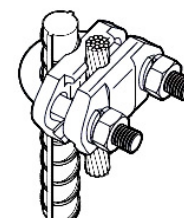

ERCL-D31-CB
ERCL-D33-CB
ERCL-D33-C
ERCL-D34-CB
ERCL-D34-C

Earth Rod To Cable Lug Clamp

- Made of copper alloy, the Earth rod to cable clamp is suitable for connecting a cable lug to an earth rod.

Rod Type: For Copper Bond

Rod Diameter (")	Weight (kg)	Material
Ø 3/8	0.03	Copper Bond
Ø 5/8	0.05	Copper Bond
Ø 5/8	0.06	Copper
Ø 3/4	0.06	Copper Bond
Ø 3/4	0.14	Copper

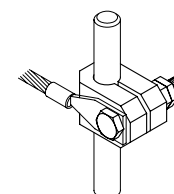



Beam To Tape Bond

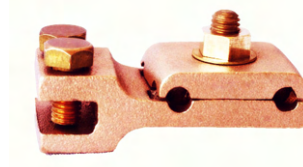

Metalwork Bond

Code

Beam To Tape Bond

For use with bare copper tape

- Made of copper or aluminium alloy, used for bonding copper or aluminium tapes to flat metal surfaces.
- Tightening Torque 17N-m

Conductor width (mm)	Material	Weight (kg)
BTB-08-C	26 Copper	0.12
BTB-08-A	26 Aluminium	0.06
BTB-10-C	31 Copper	0.15

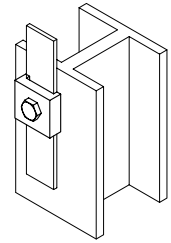

Metalwork Bond

For use with Cables

- Made of copper or aluminium alloy, used for connecting all types of metal structures (max.13mm thick).
- Tightening Torque 10N-m

Material	Weight (kg)	Conductor Size (mm)
MEB-08-C	Copper 0.37	Ø 8
MEB-08-A	Aluminium 0.17	Ø 8

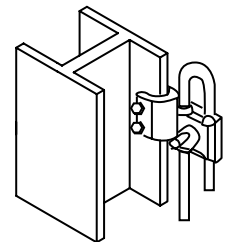

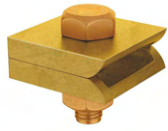

Rain Pipe To Tape Bond



Water Pipe To Tape Bond

Code

Rain Pipe To Tape Bond

For use with bare copper tape

- Made of copper and aluminium alloy, used for bonding tape to rainwater pipes.

RPTB-08-C
RPTB-08-A

Material	Weight (kg)	Conductor Width (mm)
Copper	0.12	26
Aluminium	0.07	26

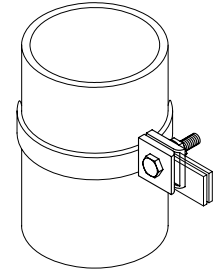

Water Pipe To Tape Bond

For use with bare copper tape

- Made of copper alloy, used for bonding metallic pipes into the earthing or lightning protection system.

WPTB-08-C

Conductor Width (mm)	Weight (kg)	Material
26	0.12	Copper

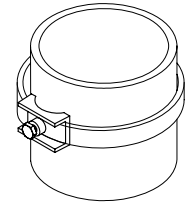



Split Bolt Connector



Re-Bar Clamp



Eye Bolt

Code

Split Bolt Connector

- Made of copper alloy.
- Used for copper to copper connections.
- No special tool is required.

	Conductor Tap (mm ²)	Conductor Size (mm)	Weight (kg)	Material
SCSB-S15	4-10	2.5-10	0.02	Copper
SCSB-S16	10-16	2.5-16	0.03	Copper
SCSB-S1	16-25	4-25	0.04	Copper
SCSB-S2	25-35	4-35	0.06	Copper
SCSB-S3	35-50	4-50	0.09	Copper
SCSB-S4	35-70	4-70	0.14	Copper
SCSB-S5	50-95	4-95	0.17	Copper
SCSB-S6	50-120	6-120	0.18	Copper
SCSB-S8	95-185	6-185	0.35	Copper

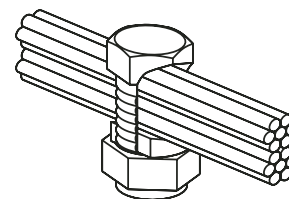

Re-Bar Clamp

- Made of copper alloy, these are used for bonding to handrails, reinforcing bars pipes etc
- Tightening Torque 15 Nm.

	Conductor Diameter	Weight (kg)	Material	Conductor Top
RBSC-D1-D1D11-C	8-18mm	0.32	Copper	8 mm
RBSC-D1-D1D15-C	8-38mm	0.75	Copper	8 mm

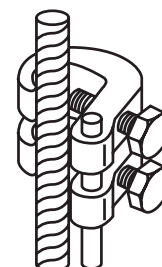

Eye Bolt

- Screws direct onto a copper bond earth rod, offering an earth point for boats, trucks etc.

	Conductor Diameter	Material	Weight (kg)
EB-D6	5/8"	Copper	0.52
EB-D10	3/4"	Copper	0.52

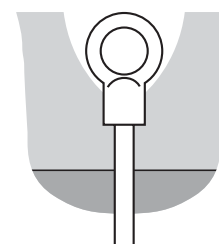



Straight Setscrew Type Cable Socket



Static Earth Receptacle

Code

Straight Setscrew Type Cable Socket

For use with Cables

- Made of copper or aluminium alloy, used for bonding copper and aluminium conductors to steel work.

	Material	Weight (kg)	Conductor Diameter (mm)
SSCS-D1-C	Copper	0.11kg	8
SSCS-D1-A	Aluminium	0.05	8

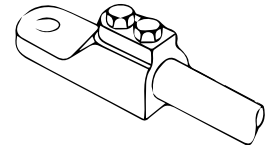

Static Earth Receptacle

Conforms to IEC 62561-2 and UL 96

- Made of copper alloy, used in open areas, roadways or runways.
- Provides a static discharge point for aircraft, fuel tankers etc.

	Weight (kg)	Material
SER-C	0.70	Copper

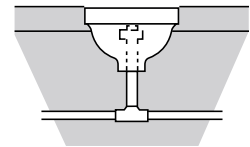



Pipe Bond



Pipe Clamp

Code

Pipe Bond

For use with bare copper tape

- Made of copper and aluminium alloy, used for bonding to the pipe and circular conductor.
- Tightening Torque 12N-m

	Material	Weight (kg)	Conductor Size (mm)	Pipe Diameter (mm)
PB-D1-C	Copper	0.46	8	50-200
PB-D1-A	Aluminium	0.25	8	50-200

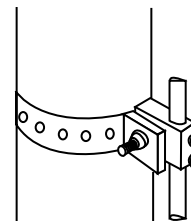

Pipe Clamp

For use with Pipes

- Made of copper alloy, used for bonding to pipe and circular conductor

	Pipe Diameter (mm)	Weight (kg)	Material	Conductor Size (mm ²)
PCL-S5-25-C	13-25	0.30	Copper	25-95
PCL-S5-50-C	32-50	0.40	Copper	25-95
PCL-S5-90-C	65-90	0.50	Copper	25-95
PCL-S5-125-C	100-125	0.60	Copper	25-95
PCL-S5-150-C	150	0.60	Copper	25-95
PCL-S5-200-C	200	1.0	Copper	25-95
PCL-S5-250-C	250	1.1	Copper	25-95
PCL-S5-300-C	300	1.5	Copper	25-95

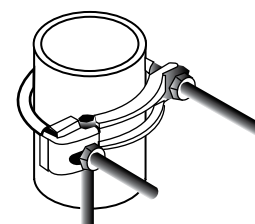

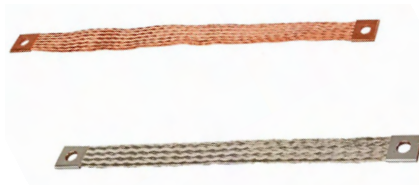

Flexible Copper Earth Braid

Code Flexible Copper Earth Braid

For use with bare copper tape

- Flexible Copper earth braid is used for bonding metal doors, gates, fences etc.
- Standard braid sizes are shown.
- Braids are available in other sizes, lengths, materials or termination to special order.

Code	Braid Dimensions (mm)	Length (mm)	Material	Hole Diameter (mm)	Weight (kg)	Cross-Sectional area (mm ²)
FEB-07-5-200-C	25 x 3	200	Copper	11	0.05	25
FEB-07-5-400-C	25 x 3	400	Copper	11	0.10	25
FEB-50-5-200-C	25 x 3.5	200	Copper	11	0.09	35
FEB-51-0-400-C	25 x 3.5	400	Copper	11	0.15	35
FEB-50-11-200-C	30 x 5	200	Copper	11	0.10	50
FEB-51-11-400-C	30 x 5	400	Copper	11	0.20	50
FEB-07-5-200-T	25 x 3	200	Tinned Copper	11	0.05	25
FEB-07-5-400-T	25 x 3	400	Tinned Copper	11	0.10	25
FEB-50-5-200-T	25 x 3.5	200	Tinned Copper	11	0.09	35
FEB-51-0-400-T	25 x 3.5	400	Tinned Copper	11	0.15	35
FEB-50-11-200-T	30 x 5	200	Tinned Copper	11	0.10	50
FEB-51-11-400-T	30 x 5	400	Tinned Copper	11	0.20	50

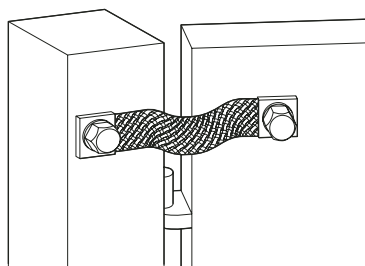

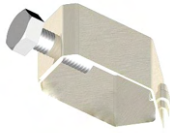

Rebar To Rebar Connecting Clip

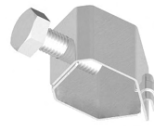

Rebar To Cable Connecting Clip

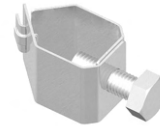

Rebar To Tape Connecting Clip

Code
RRCC-08-12
RRCC-16-16
RRCC-20-20
RRCC-25-25
RRCC-32-32
RRCC-40-40

Rebar To Rebar Connecting Clip

- Manufactured from high-quality stainless steel for excellent corrosion resistance.
- Used for connection between internal reinforcing bars.
- Simple to install.
- Tightening Torque 12 Nm

Rebar Diameter (A) (mm)	Rebar Diameter (B) (mm)	Weight (kg)
Ø 8	Ø 12	0.05
Ø 16	Ø 16	0.05
Ø 20	Ø 20	0.06
Ø 25	Ø 25	0.07
Ø 32	Ø 32	0.07
Ø 40	Ø 40	0.08

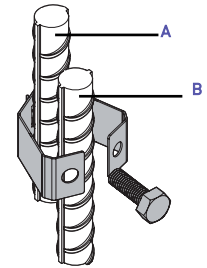

RCCC-16-S5
RCCC-16-S5
RCCC-20-S5
RCCC-35-S5
RCCC-40-S5

Rebar To Cable Connecting Clip

- Manufactured from high-quality stainless steel for excellent corrosion resistance.
- Used for connection between internal reinforcing bars.
- Simple to install.
- Tightening Torque 12 Nm

Rebar Diameter (mm)	Conductor Size (mm ²)	Weight (kg)
Ø 12	50 mm ² or Ø 8mm	0.06
Ø 16	50-95 mm ² or Ø 8mm	0.06
Ø 20	50-95 mm ² or Ø 8mm	0.07
Ø 32	50-95 mm ² or Ø 8mm	0.07
Ø 40	50-95 mm ² or Ø 8mm	0.08

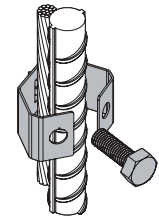

RTCC-25-07-4

Rebar To Tape Connecting Clip

- Manufactured from high-quality stainless steel for excellent corrosion resistance.
- Used for connection between internal reinforcing bars.
- Simple to install.
- Tightening Torque 12 Nm.

Rebar Diameter	Conductor Size (mm)	Weight (kg)
Ø 25	25 x 3	0.07

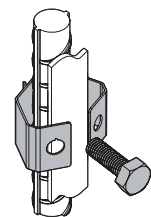



Single Hole Earth Point



Two Hole Earth Point



Four Hole Earth Point

Code
EP1-M815
EP1-M1015
EP1-M1215
EP1-M1615

Single Hole Earth Point

Conforms to IEC/BS EN 50164-1 & UL 467

- Made of copper alloy, a single hole earth point provides earthing continuity and bonding point.
- These are used for direct connection to conductors, or with additional pre-weld tail (up to 70mm² PVC insulated cable) to enable connection to internal re-bar arrangements via mechanical clamps.

Thread Size (mm)	Length (mm)	Weight (kg)
M8x15	80	0.14
M10x15	80	0.14
M12x15	80	0.14
M16x15	80	0.14

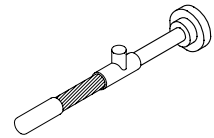

EP2-M812PS4
EP2-M812PD1
EP2-M812

Two Hole Earth Point

Conforms to IEC/BS EN 50164-1 & UL 467

- Made of copper alloy, a single hole earth point provides earthing continuity and bonding point.
- These are used for direct connection to conductors, or with additional pre-weld tail (up to 70mm² PVC insulated cable) to enable connection to internal re-bar arrangements via mechanical clamps.

Thread Size (mm)	Description	Weight (kg)
M8x12	w/front plate for the connection of 25x3mm Copper Tape or 70mm ² copper cable	0.14
M8x12	w/front plate for the connection of 25x3mm Copper Tape or 8mm solid conductor	0.14
M8x12	without front plate	0.28

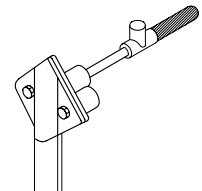

EP4-M814

Four Hole Earth Point

Conforms to IEC/BS EN 50164-1 & UL 467

- Made of copper alloy, Four hole earth point provides earthing continuity and multiple bonding point.

Thread Size (mm)	Weight (kg)	Material
M8x14	0.41	Copper

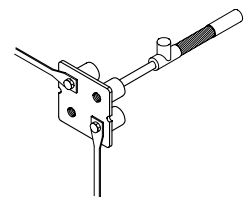

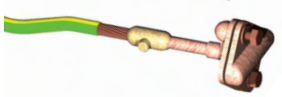

Earth Point with Pre-Welded Tail

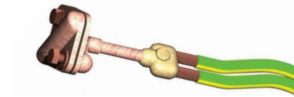

Earth Point with Two Pre-Welded Tail

Code **Earth Point with Pre-Welded Tail**

Conforms to IEC/BS EN 50164-1 & UL 467

- Tightening Torque 8Nm

Material: Copper

	Cable Size	Weight (kg)	Earth point Holes	Preweld Length (mm)
EP1-M815-S-LO-S4	70mm ² PVC insulated Cable	0.56	1	500
EP1-M1015-S-LO-S4	70mm ² PVC insulated Cable	0.56	1	500
EP1-M1215-S-LO-S4	70mm ² PVC insulated Cable	0.56	1	500
EP1-M1615-S-LO-S4	70mm ² PVC insulated Cable	0.56	1	500
EP2-M812PS4-S-LO-S4	70mm ² PVC insulated Cable	0.84	2	500
EP2-M812PD1-S-LO-S4	70mm ² PVC insulated Cable	0.84	2	500
EP2-M812-S-LO-S4	70mm ² PVC insulated Cable	0.75	2	500
EP4-M814-S-LO-S4	70mm ² PVC insulated Cable	1.14	4	500

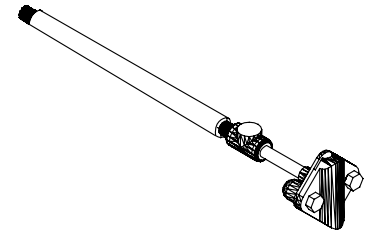

Earth Point with Double Pre-Welded Tail

- Tightening Torque 8 N-m

Material: Copper

	Cable Size	Preweld Length (mm)	Weight (kg)
HZ2-M812PD1-D-LO-S4	70mm ² PVC insulated Cable	2 x 500	1.30
HZ2-M812-D-LO-S4	70mm ² PVC insulated Cable	2 x 500	1.30
HZ4-M814-D-LO-S4	70mm ² PVC insulated Cable	2 x 500	1.30

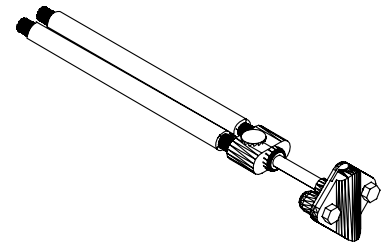



Copper Earth Bar



Telecommunication Earth Bars



Based Earth Bar with GI C-Clamp



Based Earth Bar with PVC Base

Code

Earth Bars and Disconnecting links

Conforms to IEC 62561-1 and UL 467

SEICO earth bars are an essential and convenient way of providing a common earth point, and integral disconnecting links allow easy isolation for testing purposes.

- Our earth bars are available in a variety of sizes and specifications.
- Our Standard earth bars are shown in the upcoming tables.
- Special earth bar manufactured to customer requirements are also available.
- Consist of a 50x6mm copper bar with Brass M10 termination screws, M10 Insulator and HDG base.

Copper Earth Bar - Single

	Length (mm)	Number of Ways	Hole Diameter	Width x Thickness (mm)
EBS-L0136-8W-D3	500	8	Ø 10 mm	40x4
EBS-L0148-8W-D3	500	8	Ø 10 mm	50x6
EBS-L1148-10W-D3	600	10	Ø 10 mm	50x6
EBS-L2148-10-WD5	900	10	Ø 12.8 mm	50x6
EBS-L3148-16W-D5	1000	16	Ø 12.8 mm	50x6
EBS-L4148-18W-D6	1200	18	Ø 14.2 mm	50x6
EBS-L5148-20W-D6	1500	20	Ø 14.2 mm	50x6
EBS-L6148-26W-D9	1800	26	Ø 16 mm	50x6
EBS-L7148-30W-D9	2000	30	Ø 16 mm	50x6

Based Earth Bar - Copper

	Length (mm)	Number of Ways	Weight (kg)	Width x Height (mm)
EB-6W-C	400	6	1.80	90x90
EB-8W-C	500	8	2.20	90x90
EB-10W-C	650	10	2.80	90x90
EB-12W-C	750	12	3.20	90x90
EB-14W-C	850	14	3.60	90x90
EB-16W-C	950	16	4.00	90x90
EB-18W-C	1050	18	4.40	90x90
EB-20W-C	1200	20	5.00	90x90
EB-22W-C	1300	22	5.40	90x90
EB-24W-C	1400	24	5.80	90x90
EB-26W-C	1500	26	6.20	90x90
EB-28W-C	1650	28	6.90	90x90
EB-30W-C	1750	30	7.30	90x90

Based Earth Bar - Tinned

	Length (mm)	Number of Ways	Weight (kg)	Width x Height (mm)
EB-6W-T	400	6	1.80	90x90
EB-8W-T	500	8	2.20	90x90
EB-10W-T	650	10	2.80	90x90
EB-12W-T	750	12	3.20	90x90
EB-14W-T	850	14	3.60	90x90
EB-16W-T	950	16	4.00	90x90
EB-18W-T	1050	18	4.40	90x90
EB-20W-T	1200	20	5.00	90x90
EB-22W-T	1300	22	5.40	90x90
EB-24W-T	1400	24	5.80	90x90
EB-26W-T	1500	26	6.20	90x90
EB-28W-T	1650	28	6.90	90x90
EB-30W-T	1750	30	7.30	90x90



Earth Bar with Single Disconnecting Link



Flat Plate Bar

Code

Earth Bar with Single Disconnecting Link - Copper

Conforms to BS 7430 and IEC 62561-1

- Consists of a 50x6mm copper bar with Brass M10 termination screws, M10 Insulator and HDG/PVC base.

	Length (mm)	Number of Ways	Weight (kg)	Width x Height (mm)
EBSDL-6W-C	475	6	2.30	90 x 96
EBSDL-8W-C	575	8	2.70	90 x 96
EBSDL-10W-C	725	10	3.30	90 x 96
EBSDL-12W-C	825	12	3.70	90 x 96
EBSDL-14W-C	925	14	4.10	90 x 96
EBSDL-16W-C	1025	16	4.50	90 x 96
EBSDL-18W-C	1125	18	4.90	90 x 96
EBSDL-20W-C	1275	20	5.50	90 x 96
EBSDL-22W-C	1375	22	5.90	90 x 96
EBSDL-24W-C	1475	24	6.30	90 x 96
EBSDL-26W-C	1575	26	6.70	90 x 96
EBSDL-28W-C	1725	28	7.40	90 x 96
EBSDL-30W-C	1825	30	7.80	90 x 96

Earth Bar with Single Disconnecting Link - Tinned

	Length (mm)	Number of Ways	Weight (kg)	Width x Height (mm)
EBSDL-6W-T	475	6	2.30	90 x 96
EBSDL-8W-T	575	8	2.70	90 x 96
EBSDL-10W-T	725	10	3.30	90 x 96
EBSDL-12W-T	825	12	3.70	90 x 96
EBSDL-14W-T	925	14	4.10	90 x 96
EBSDL-16W-T	1025	16	4.50	90 x 96
EBSDL-18W-T	1125	18	4.90	90 x 96
EBSDL-20W-T	1275	20	5.50	90 x 96
EBSDL-22W-T	1375	22	5.90	90 x 96
EBSDL-24W-T	1475	24	6.30	90 x 96
EBSDL-26W-T	1575	26	6.70	90 x 96
EBSDL-28W-T	1725	28	7.40	90 x 96
EBSDL-30W-T	1825	30	7.80	90 x 96

Flat Plate Bar

- Used to connect to the structure through welding. This then can be connected to the ground.

Conforms to IEC 62561-1 and UL 467

	Length (mm)	Thickness (mm)
FPB-50-BS	50	6
FPB-75-BS	75	6
FPB-150-BS	150	6
FPB-50-SS	50	6
FPB-75-SS	75	6
FBP-150-SS	150	6
FPB-50-C	50	6
FPB-75-C	75	6
FPB-150-C	150	6

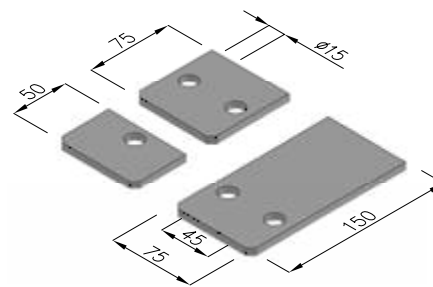



Earth Bar with Twin Disconnecting Link

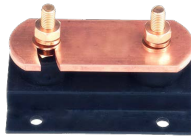

Disconnecting Link



Swan Neck Link

Code

Earth Bar with Twin Disconnecting Link - Copper

Conforms to IEC 62561-1 and UL 467

	Length (mm)	Number of Ways	Weight (kg)	Width x Height (mm)
EBTDL-6W-C	550	6	2.80	90 x 96
EBTDL-8W-C	650	8	3.20	90 x 96
EBTDL-10W-C	800	10	3.80	90 x 96
EBTDL-12W-C	900	12	4.20	90 x 96
EBTDL-14W-C	1000	14	4.60	90 x 96
EBTDL-16W-C	1100	16	5.00	90 x 96
EBTDL-18W-C	1200	18	5.40	90 x 96
EBTDL-20W-C	1350	20	6.00	90 x 96
EBTDL-22W-C	1450	22	6.40	90 x 96
EBTDL-24W-C	1550	24	6.80	90 x 96
EBTDL-26W-C	1650	26	7.20	90 x 96
EBTDL-28W-C	1800	28	7.90	90 x 96
EBTDL-30W-C	1900	30	8.30	90 x 96

Copper Earth Bar - Tinned

	Length (mm)	Number of Ways	Weight (kg)	Width x Height (mm)
EBTDL-6W-T	550	6	2.80	90 x 96
EBTDL-8W-T	650	8	3.20	90 x 96
EBTDL-10W-T	800	10	3.80	90 x 96
EBTDL-12W-T	900	12	4.20	90 x 96
EBTDL-14W-T	1000	14	4.60	90 x 96
EBTDL-16W-T	1100	16	5.00	90 x 96
EBTDL-18W-T	1200	18	5.40	90 x 96
EBTDL-20W-T	1350	20	6.00	90 x 96
EBTDL-22W-T	1450	22	6.40	90 x 96
EBTDL-24W-T	1550	24	6.80	90 x 96
EBTDL-26W-T	1650	26	7.20	90 x 96
EBTDL-28W-T	1800	28	7.90	90 x 96
EBTDL-30W-T	1900	30	8.30	90 x 96

Earth Bar Accessories

Conforms to IEC 62561-2 and UL 467

- The disconnecting link provides a temporary break in the earth connection to allow inspection and testing of the earth electrode.

	Length (mm)	Width (mm)	Height (mm)	Weight (kg)	Description
SNL	200	50	6	0.59	Swan Neck Link
DL	200	90	96	0.42	Disconnecting Link



C-Crimp

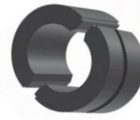

Die to Suit Hydraulic Crimping Tool

Code

C-Crimp Connector

Conforms to BS EN IEC 62561-1 and UL 467

- Made of pure electrolytic copper and also available in tinned plating.
- Used for parallel or tap connection over cables.

Material: Copper / Tinned Copper

	Conductor Size (Main) (mm ²)	Conductor Size (Tap) (mm ²)	Weight (kg)
CCC-10-10-C	10	1.5-10	0.06
CCC-16-16-C	16	1.5-16	0.19
CCC-25-10-C	25	1.5-10	0.21
CCC-25-25-C	25	16-25	0.22
CCC-35-16-C	35	1.5-16	0.39
CCC-35-35-C	35	25-35	0.39
CCC-50-25-C	50	4-25	0.90
CCC-50-50-C	50	35-50	0.90
CCC-70-25-C	70	1.5-25	0.36
CCC-70-35-C	70	4-35	0.97
CCC-70-70-C	70	35-70	0.91
CCC-95-35-C	95	4-35	0.95
CCC-95-70-C	95	35-70	0.98
CCC-95-95-C	95	70-95	1.05
CCC-120-120-C	120	25-120	1.20
CCC-150-120-C	150	25-120	1.22
CCC-150-150-C	150	70-150	1.25
CCC-185-95-C	185	16-95	1.30
CCC-185-185-C	185	120-185	1.35
CCC-240-120-C	240	95-120	1.60
CCC-240-240-C	240	240-240	1.72
CCC-300-120-C	300	300-120	1.85
CCC-300-300-C	300	300-300	2.01

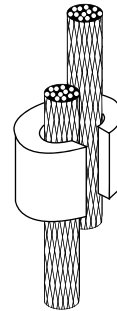

Die to Suit Hydraulic Crimping Tool

	Conductor Size (Main) (mm ²)	Conductor Size (Tap) (mm ²)	Weight (kg)
DHCT-100	10	1.5-10	1.70
DHCT-200	16	1.5-16	1.70
DHCT-200	16-25	1.5-10	1.60
DHCT-200	25	16-25	1.60
DHCT-300	35	1.5-16	1.60
DHCT-300	35	25-35	1.60
DHCT-300	70	1.5-25	1.50
DHCT-400	50	4-25	1.50
DHCT-400	50	35-50	1.50
DHCT-400	50-70	4-35	1.50
DHCT-400	50-70	35-70	1.50
DHCT-500	95	4-35	1.40
DHCT-500	95	35-70	1.40
DHCT-500	95	70-95	1.40
DHCT-600	120	25-120	1.25
DHCT-600	150	25-120	1.25
DHCT-600	150	70-150	1.25
DHCT-600	185	16-95	1.25



Compression Lugs

Code

Compression Lugs

Conforms to BS EN IEC 62561-1 and UL 467

Material: Tinned Copper

Code	Conductor Size (mm ²)	Screw Size (mm)	Weight (kg)
SCLT-16-06	16	6	0.01
SCLT-16-08	16	8	0.01
SCLT-16-10	16	10	0.01
SCLT-25-06	25	6	0.01
SCLT-25-08	25	8	0.01
SCLT-25-10	25	10	0.01
SCLT-35-06	35	6	0.01
SCLT-35-08	35	8	0.01
SCLT-35-10	35	10	0.01
SCLT-50-08	50	8	0.02
SCLT-50-10	50	10	0.02
SCLT-50-12	50	12	0.02
SCLT-70-08	70	8	0.04
SCLT-70-10	70	10	0.04
SCLT-70-12	70	12	0.04
SCLT-70-14	70	14	0.04
SCLT-70-16	70	16	0.04
SCLT-95-08	95	8	0.06
SCLT-95-10	95	10	0.06
SCLT-95-12	95	12	0.06
SCLT-70-14	70	14	0.04
SCLT-70-16	70	16	0.04
SCLT-95-08	95	8	0.06
SCLT-95-12	95	12	0.06
SCLT-95-14	95	14	0.06
SCLT-95-16	95	16	0.06
SCLT-120-10	120	10	0.06
SCLT-120-12	120	12	0.06
SCLT-120-14	120	14	0.06
SCLT-120-16	120	16	0.06
SCLT-150-10	150	10	0.09
SCLT-150-12	150	12	0.09
SCLT-150-14	150	14	0.09
SCLT-150-16	150	16	0.09
SCLT-185-12	185	12	0.11
SCLT-185-14	185	14	0.11
SCLT-185-16	185	16	0.11
SCLT-240-12	240	12	0.14
SCLT-240-14	240	14	0.14
SCLT-240-16	240	16	0.14
SCLT-300-12	300	12	0.17
SCLT-300-14	300	14	0.17
SCLT-300-16	300	16	0.17
SCLT-400-12	400	12	0.21
SCLT-400-14	400	14	0.21
SCLT-400-16	400	16	0.21
SCLT-500-16	500	16	0.28
SCLT-630-16	630	16	0.35

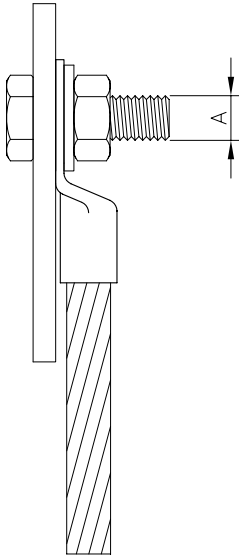



Insulator



PVC Bush



Earth Boss

Code**Insulator**

- Insulator manufactured from red/grey GRP material with brass insert

	Thread Size	Weight (kg)	Height (mm)	For Copper Bar Size (mm)
INSLTR-M6-20	M6	0.10	20	25x3
INSLTR-M6-30	M6	0.10	30	25x6
INSLTR-M8-40	M8	0.14	40	38x6
INSLTR-M10-50	M10	0.16	50	50x6
INSLTR-M10-60	M10	0.16	60	75x6
INSLTR-M12-70	M12	0.18	70	100x6

PVC Bush

- Bush made up of black PVC, alternative for Busbar Insulators

	Thread Size	Weight (kg)	Height (mm)
BUSH-M10-20	M10	0.10	20

Earth Boss

- Made of mild steel with stud and nuts. Used for welding steel structures.

	Thread	Diameter	Weight (kg)
EAB-M10-50	M10	50mm	0.80

EXOTHERMIC WELDING SYSTEM

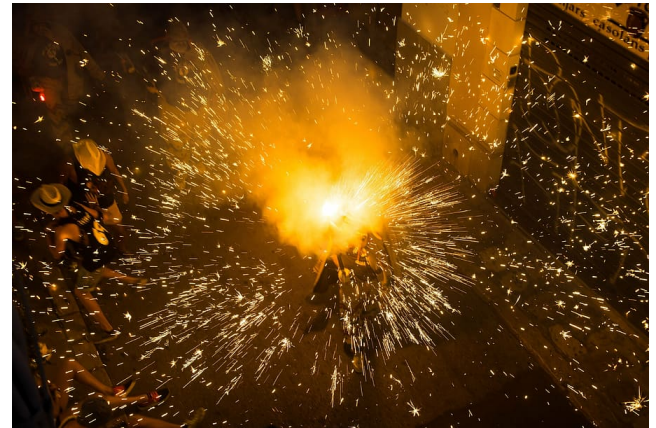

Exothermic welding is an innovative new way to connect two metals.

SEICOWeld Exothermic System uses the high-temperature reaction of copper oxide and aluminium inside a semi-permanent graphite mould, to form electrical connections (mainly between copper and copper or copper and steel).

No outside source of power or heat is needed when using the exothermic system.

It is light and completely portable, making it ideal for field use. Creating an exothermic joint is a simple procedure which requires a mould, welding powder, handle clamp and various tools and cleaning accessories.

Typical Applications include:

- Sub Stations and Power Plants
- T&D Distribution Lines
- Rail Connections
- Telecommunications

Features:

- 1 High current carrying capacity
- 2 High current surge resistance
- 3 Sparkles connections
- 4 Stable transition resistance
- 5 High corrosion resistance
- 6 Good mechanical parameters
- 7 Quick connection time
- 8 Lightweight (kg) equipment needed
- 9 Can be used safely with minimum training
- 10 Can be used for over 45 standard connection configurations.
- 11 Completely portable

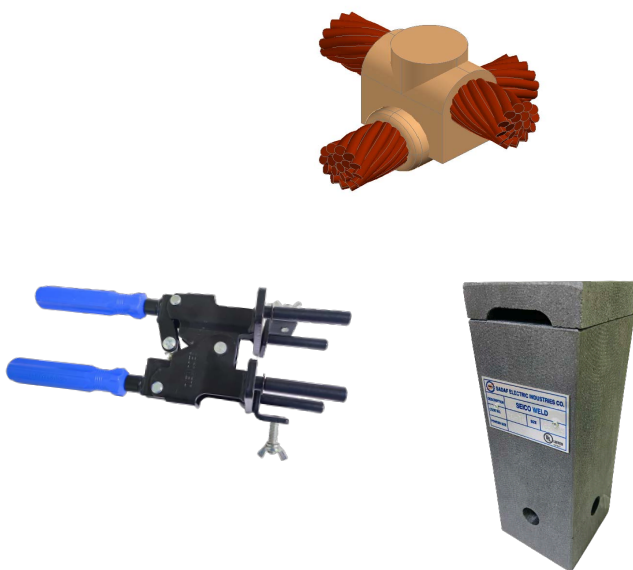



BS EN 62561-1

UL-467

MOULDS:

The **SEICOWeld** system of exothermic welding uses moulds (to contain the exothermic reaction) for creating safe and robust connections. Different types of moulds are available (use depends on the requirements of the project). These moulds can be used for cable to cable connections, cable to a rod, rod to rod connections, cable to reinforcing bar connections, bar to bar and bar to earth rod connections.

Graphite Moulds:

Market-leading SEICO WELD graphite moulds are extremely robust and capable of producing over 45 connections each.

SEICO WELD Powders:

Our powders are a high-quality mixture of copper oxide and aluminium, inside plastic cartridges, and include the required metal retaining disc. Each SEICOWeld connection uses one disc. The starting powder is compacted at the bottom of each cartridge and the Safeweld powder is on top. Starting powder is released by firmly tapping the base of the cartridge. SEICOWeld powder is not explosive, shock-sensitive or subject to spontaneous combustion and is supplied in the following pack sizes: 25g | 32g | 45g 65g | 90g | 115g 150g | 200g | 250g.

Handle Clamps:

SEICOWeld Handle Clamps are required to hold graphite moulds and conductors in place while the connection is being made. Three sizes of Handle Clamps cover the range of connections which can be made.

SEICO WELD Tool Kit:

Includes these important tools and cleaning materials to aid your welding program:

- Tape cleaning brush
- Cable cleaning brush
- Mould cleaning brush
- Mould cleaning scraper
- Flint gun
- Replacement flints
- Disc container
- Duxseal Jointing Compound (1lb)
- Butane torch
- Heat resistant gloves
- Optical safety glasses

SEICO WELD Tool Kit for Bar Connections:**Includes:**

- Tape cleaning brush
- Mould cleaning brush
- Mould cleaning scraper
- Flint gun

SEICO WELD Tool Kit for cable connections:**Includes:**

- Tape Cleaning Brush
- Cable Cleaning Brush
- Mould Cleaning Brush
- Mould Cleaning Scraper
- Flint Gun

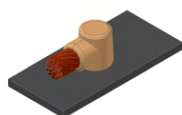

CABLE TO STEEL SURFACE & PIPE

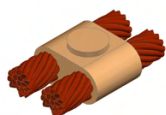

CABLE TO CABLE CONNECTION

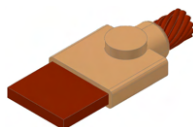

CABLE TO TAPE CONNECTION

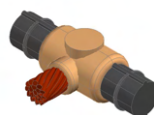

CABLE TO REINFORCING BAR

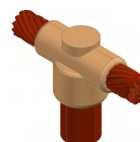

CABLE TO EARTHROD CONNECTIONS

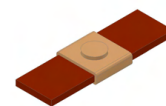

TAPE TO TAPE CONNECTION

WELD CONNECTION

Conforms to IEC 62561-1 and UL 467

SEICOWeld Connection Tips

When making a copper wire connection for ground rods or other materials, put the **SEICOWeld** powder into the graphite mould. You only need to ignite it to start the welding process. The result will be a clean and smooth connection surface, which has been field proven. It can also be used on other metals, such as: Iron, steel, railway track, wrought and cast iron, bronze, nichrome and bronze.

SEICOWeld exothermic welding can be used in various applications to ensure excellent working connections. Many professionals trust in **SEICOWeld** for:

- Lightning and surge protection
- Grounding electrical works
- Railway construction
- Cathodic construction

TYPES OF MOULDS

Conforms to IEC 62561-1 and UL 467

SEICOWeld Connection Tips

SEICOWeld offers more than one type of moulds. There are "One Time Moulds" and "Graphite Moulds" with different shapes to suit different welding needs. "ONE TIME MOULD" is made of ceramic suitable for "One Off" welding work. "GRAPHITE MOULD" is made of high quality graphite suitable for quality welding work and can be used several times. It provides the following advantages:

1. A smooth metal connection that will not loosen or corrode.
2. Not affected by high current surge or over current.
3. No need for an external welding machine.
4. Can use lightWeight (kg) and cheap equipment.
5. Virtually maintenance free

SEICO MOULD PARTS AND CROSS-SECTION

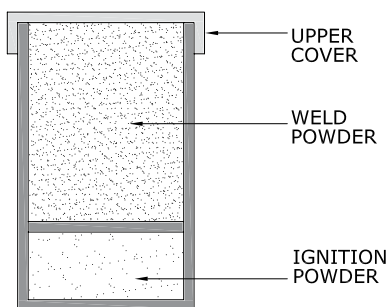
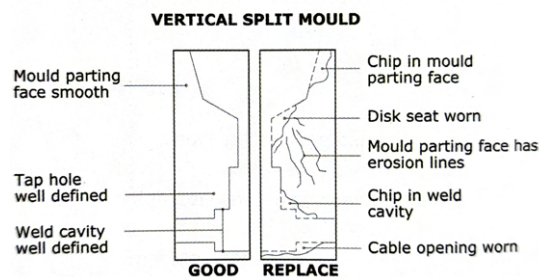
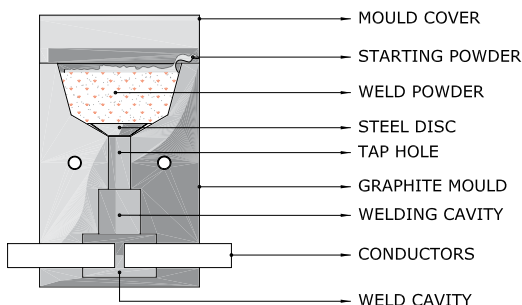

SEICOWELD Powder Selection	
P - 15	P - 115
P - 25	P - 150
P - 32	P - 200
P - 45	P - 250
P - 65	P - 2 x 150
P - 90	P - 2 x 200
	P - 2 x 250

WELDING SYSTEM INSTRUCTION STEPS

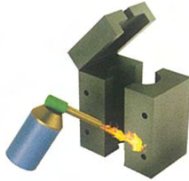
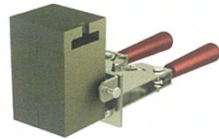
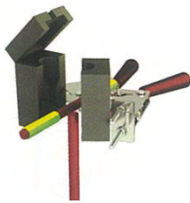
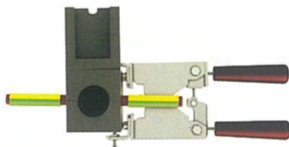
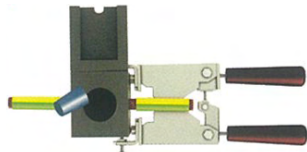
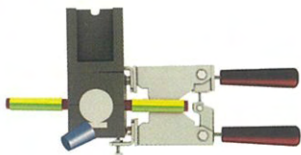
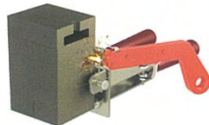
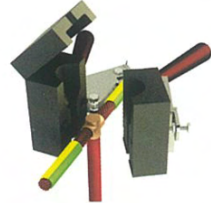
<p>1</p>  <p>When using insulated cables, first remove 150mm of the conductor insulation and clean away all the dust and oxides with the mould brush, and/or card cloth brush.</p>	<p>2</p>  <p>Preheat the welding mould with a welding torch or ignite a box of welding powder to remove the moisture, before starting the first weld.</p>	<p>3</p>  <p>Connect the handle clamp to the hole and separate the two arms to open the mould. Next, fit the conductors and leave a 5- 6mm gap on the other conductor</p>
<p>4</p>  <p>Close the mould with the handle clamp and put the STEEL DISC on the top hole (the conical side of the disc should be at the bottom)</p>	<p>5</p>  <p>Pour the weld powder into the crucible (located in the upper portion of the powder box).</p>	<p>6</p>  <p>The ignition powder is located on the bottom of the powder canister. Put it on the lip of the crucible and on top of the weld powder to simplify powder ignition</p>
<p>7</p>  <p>Ignite the flint ignitor beside the ignition powder. Pull away the flint ignitor once it ignites to avoid damage.</p>	<p>8</p>  <p>After one minute, separate the two arms of the handle clamp to open completely. Extra care should be taken so you don't damage the mould.</p>	<p>9</p>  <p>Completely clean the mould by using the mould scraper and mould brush. You can continue welding as long as the mould is still warm.</p>

Conductor Selection Table

Conductor Size	Number of Wires per Diameter	Overall Diameter
10mm ²	7x 1.35mm	4.10mm
16mm ²	7x1.70mm	5.10mm
25mm ²	7x2.10mm	6.30mm
35mm ²	7x2.50mm	7.50mm
50mm ²	19x1.80mm	9.00mm
70mm ²	19 x 2.10mm	10.50mm
95mm ²	19x2.52mm	12.50mm
120mm ²	19x2.80mm	14.00mm
150mm ²	37x2.25mm	15.70mm
185mm ²	37x2.50mm	17.50mm
240mm ²	61 x2.25mm	20.20mm
300mm ²	61 x2.50mm	22.50mm
400mm ²	61 x2.89mm	26.00mm
500mm ²	61 x3.23mm	29.10mm

Concrete Steel Re-Bar	
Normal Size	Overall Dia
6mm	7.20mm
8mm	9.60mm
10mm	12.00mm
12mm	14.40mm
14mm	16.80mm
16mm	19.20mm
20mm	24.00mm
25mm	30.00mm
32mm	38.40mm

Standard Overall Dia for Earth Rod	
Actual	Nominal" (mm)
14.3mm	5/8" (15.88)
17.2mm	3/4"(19.05)
12.7mm	1/2"

EXOTHERMIC WELDING MOULDS are designed and manufactured to fit different types and sizes of copper conductors, earth rods & concrete steel re-bar.

HOW TO ORDER:

Choose the appropriate connection from our SEICO-Weld Connection Chart. Check your run cable size. The cell where the two sections meet, shows the powder size needed to carry out the connections.

Example :

If you require CABLE to CABLE (Straight Horizontal) If you need CABLE to CABLE (straight horizontal) with 35mm² and 150mm² conductors, you should

Order:

1. CC-L-150-35 (Mould Catalogue No.)
 2. P- 90 (Powder Catalogue No.)
- See table for clarification.

Other types and sizes are available upon request.



STRAIGHT HORIZONTAL (CC-L)

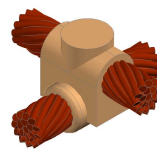

HORIZONTAL CROSS TAP (CC-XS)

CABLE TO CABLE CONNECTION (Straight)

Conforms to IEC 62561-1 and UL 467

Code	Stranded/Solid Circular Conductor Size (A) (mm ²)	Powder	Handle Clamp
CC-L-16	16	P-32	HC-M
CC-L-25	25	P-32	HC-M
CC-L-35	35	P-32	HC-M
CC-L-50	50	P-45	HC-M
CC-L-70	70	P-65	HC-M
CC-L-95	95	P-90	HC-M
CC-L-120	120	P-115	HC-M
CC-L-150	150	P-115	HC-M
CC-L-185	185	P-150	HC-M
CC-L-240	240	P-200	HC-M
CC-L-300	300	P-250	HC-M
CC-L-400	400	P-2x150	HC-L

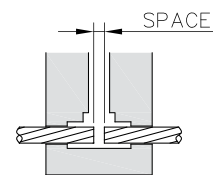

CABLE TO CABLE CONNECTION (HORIZONTAL CROSS TAP)

Conforms to IEC 62561-1 and UL 467

Code	Stranded/Solid Circular Conductor Size (A) (mm ²)	Stranded/Solid Circular Conductor Size (B) (mm ²)	Powder	Handle Clamp
CC-XS-50-50	50	50	P-150	HC-M
CC-XS-70-70	70	70	P-200	HC-M
CC-XS-95-95	95	95	P-250	HC-M
CC-XS-120-120	120	120	P-2x150	HC-M
CC-XS-150-150	150	150	P-2x200	HC-L
CC-XS-185-185	185	185	P-2x250	HC-L
CC-XS-240-240	240	240	P-3x200	HC-L
CC-XS-300-300	300	300	P-3x250	HC-L



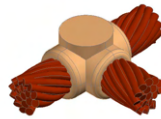

TEE HORIZONTAL (CC-TH)

Code	CABLE TO CABLE CONNECTION (TEE)			
	Conforms to IEC 62561-1 and UL 467			
	Stranded/Solid Circular Conductor Size (A) (mm ²)	Stranded/Solid Circular Conductor Size (B) (mm ²)	Powder	Handle Clamp
CC-TH-16-16	16	16	P-45	HC-M
CC-TH-25-25	25	25	P-45	HC-M
CC-TH-35-35	35	35	P-45	HC-M
CC-TH-50-50	50	50	P-90	HC-M
CC-TH-50-35	50	35	P-65	HC-M
CC-TH-50-25	50	25	P-65	HC-M
CC-TH-70-70	70	70	P-90	HC-M
CC-TH-70-50	70	50	P-90	HC-M
CC-TH-70-35	70	35	P-65	HC-M
CC-TH-70-25	70	25	P-65	HC-M
CC-TH-95-95	95	95	P-115	HC-M
CC-TH-95-70	95	70	P-90	HC-M
CC-TH-95-50	95	50	P-90	HC-M
CC-TH-95-35	95	35	P-90	HC-M
CC-TH-120-120	120	120	P-150	HC-M
CC-TH-120-95	120	95	P-150	HC-M
CC-TH-120-70	120	70	P-90	HC-M
CC-TH-120-50	120	50	P-90	HC-M
CC-TH-150-150	150	150	P-200	HC-M
CC-TH-150-120	150	120	P-150	HC-M
CC-TH-150-95	150	95	P-150	HC-M
CC-TH-150-70	150	70	P-90	HC-M
CC-TH-185-185	185	185	P-200	HC-M
CC-TH-185-150	185	150	P-200	HC-M
CC-TH-185-120	185	120	P-200	HC-M
CC-TH-240-240	240	240	P-2x150	HC-M
CC-TH-240-150	240	150	P-200	HC-M
CC-TH-240-120	240	120	P-200	HC-M
CC-TH-300-300	300	300	P-2x200	HC-L
CC-TH-300-240	300	240	P-2x200	HC-L

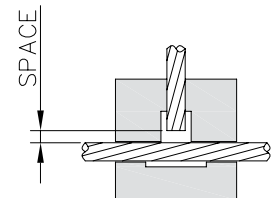

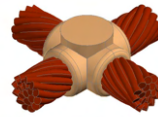

HORIZONTAL CROSS (CC-X)

Code	CABLE TO CABLE CONNECTION (CROSS)			
	Conforms to IEC 62561-1 and UL 467			
	Stranded/Solid Circular Conductor Size (A) (mm ²)	Stranded/Solid Circular Conductor Size (B) (mm ²)	Powder	Handle Clamp
CC-X-16-16	16	16	P-65	HC-M
CC-X-25-25	25	25	P-45	HC-M
CC-X-35-35	35	35	P-65	HC-M
CC-X-50-50	50	50	P-90	HC-M
CC-X-50-35	50	35	P-90	HC-M
CC-X-50-25	50	25	P-90	HC-M
CC-X-70-70	70	70	P-115	HC-M
CC-X-70-50	70	50	P-115	HC-M
CC-X-70-35	70	35	P-115	HC-M
CC-X-70-25	70	25	P-115	HC-M
CC-X-95-95	95	95	P-150	HC-M
CC-X-95-70	95	70	P-150	HC-M
CC-X-95-50	95	50	P-115	HC-M
CC-X-95-35	95	35	P-115	HC-M
CC-X-120-120	120	120	P-200	HC-M
CC-X-120-95	120	95	P-200	HC-M
CC-X-120-70	120	70	P-150	HC-M
CC-X-120-50	120	50	P-150	HC-M
CC-X-150-150	150	150	P-250	HC-M
CC-X-150-120	150	120	P-250	HC-M
CC-X-150-95	150	95	P-200	HC-M
CC-X-150-70	150	70	P-150	HC-M
CC-X-185-185	185	185	P-2x150	HC-M
CC-X-185-150	185	150	P-250	HC-M
CC-X-185-120	185	120	P-250	HC-M
CC-X-240-240	240	240	P-2x250	HC-L
CC-X-240-150	240	150	P-2x200	HC-L
CC-X-240-120	240	120	P-2x150t0	HC-L
CC-X-300-300	300	300	P-2x200	HC-L
CC-X-300-240	300	240	P-2x250	HC-L

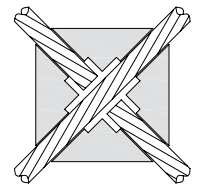

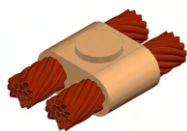

DOUBLE HORIZONTAL (CC-DPH)

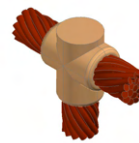

TEE VERTICAL (CC-TV)

CABLE TO CABLE CONNECTION (DOUBLE HORIZONTAL)

Conforms to IEC 62561-1 and UL 467

Code	Stranded/Solid Circular Conductor Size (A) (mm ²)	Stranded/Solid Circular Conductor Size (B) (mm ²)	Powder	Handle Clamp
CC-DPH-16-16	16	16	P-65	HC-M
CC-DPH-25-25	25	25	P-45	HC-M
CC-DPH-35-35	35	35	P-65	HC-M
CC-DPH-50-50	50	50	P-90	HC-M
CC-DPH-50-35	50	35	P-90	HC-M
CC-DPH-50-25	50	25	P-90	HC-M
CC-DPH-70-70	70	70	P-115	HC-M
CC-DPH-70-50	70	50	P-115	HC-M
CC-DPH-70-35	70	35	P-90	HC-M
CC-DPH-70-25	70	25	P-90	HC-M
CC-DPH-95-95	95	95	P-150	HC-M
CC-DPH-95-70	95	70	P-150	HC-M
CC-DPH-95-50	95	50	P-150	HC-M
CC-DPH-95-35	95	35	P-115	HC-M
CC-DPH-120-120	120	120	P-200	HC-M
CC-DPH-120-95	120	95	P-200	HC-M
CC-DPH-120-70	120	70	P-200	HC-M
CC-DPH-120-50	120	50	P-150	HC-M

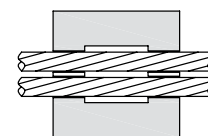

CABLE TO CABLE CONNECTION (TEE VERTICAL)

Conforms to IEC 62561-1 and UL 467

Code	Stranded/Solid Circular Conductor Size (A) (mm ²)	Stranded/Solid Circular Conductor Size (B) (mm ²)	Powder	Handle Clamp
CC-TV-16-16	16	16	P-45	HC-M
CC-TV-25-25	25	25	P-45	HC-M
CC-TV-35-35	35	35	P-45	HC-M
CC-TV-50-50	50	50	P-90	HC-M
CC-TV-70-70	70	70	P-90	HC-M
CC-TV-70-50	70	50	P-90	HC-M
CC-TV-95-95	95	95	P-115	HC-M
CC-TV-95-70	95	70	P-90	HC-M
CC-TV-95-50	95	50	P-90	HC-M
CC-TV-120-120	120	120	P-150	HC-M
CC-TV-120-95	120	95	P-150	HC-M
CC-TV-120-70	120	70	P-90	HC-M
CC-TV-120-50	120	50	P-90	HC-M
CC-TV-150-150	150	150	P-200	HC-M
CC-TV-150-120	150	120	P-150	HC-M
CC-TV-150-95	150	95	P-150	HC-M
CC-TV-185-185	185	185	P-200	HC-M
CC-TV-185-150	185	150	P-200	HC-M
CC-TV-185-120	185	120	P-200	HC-M
CC-TV-240-240	240	240	P-2x150	HC-M

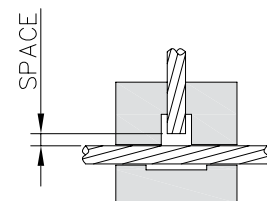



STRAIGHT VERTICAL (CP-V)

Code	CABLE TO EARTH ROD CONNECTION (Straight Vertical)				
Conforms to IEC 62561-1					
	EARTH ROD (A) Ø (mm)	EARTH ROD (B) Ø (")	Stranded/Solid Circular Conductor Size (C) (mm²)	Powder	Handle Clamp
CP-V-127-16	12.7	1/2	16	P-90	HC-M
CP-V-127-25	12.7	1/2	25	P-90	HC-M
CP-V-127-35	12.7	1/2	35	P-90	HC-M
CP-V-127-50	12.7	1/2	50	P-90	HC-M
CP-V-127-70	12.7	1/2	70	P-90	HC-M
CP-V-127-95	12.7	1/2	95	P-115	HC-M
CP-V-127-120	12.7	1/2	120	P-150	HC-M
CP-V-142-16	14.2	5/8	16	P-90	HC-M
CP-V-142-25	14.2	5/8	25	P-90	HC-M
CP-V-142-35	14.2	5/8	35	P-90	HC-M
CP-V-142-50	14.2	5/8	50	P-90	HC-M
CP-V-142-70	14.2	5/8	70	P-115	HC-M
CP-V-142-95	14.2	5/8	95	P-115	HC-M
CP-V-142-120	14.2	5/8	120	P-150	HC-M
CP-V-142-150	14.2	5/8	150	P-200	HC-M
CP-V-142-185	14.2	5/8	185	P-200	HC-M
CP-V-142-240	14.2	5/8	240	P-250	HC-M
CP-V-172-16	17.2	3/4	16	P-90	HC-M
CP-V-172-25	17.2	3/4	25	P-90	HC-M
CP-V-172-35	17.2	3/4	35	P-90	HC-M
CP-V-172-50	17.2	3/4	50	P-115	HC-M
CP-V-172-70	17.2	3/4	70	P-115	HC-M
CP-V-172-95	17.2	3/4	95	P-115	HC-M
CP-V-172-120	17.2	3/4	120	P-150	HC-M
CP-V-172-150	17.2	3/4	150	P-200	HC-M
CP-V-172-185	17.2	3/4	185	P-200	HC-M
CP-V-172-240	17.2	3/4	240	P-250	HC-M
CP-V-172-300	17.2	3/4	300	P-2x150	HC-L

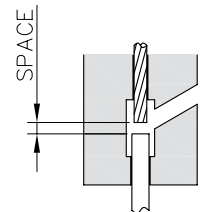

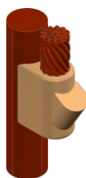

ONE SIDE VERTICAL (CP-VS)

Code	CABLE TO EARTH ROD CONNECTION (One Side Vertical)				
	Conforms to IEC 62561-1				
	EARTH ROD (B) Ø (mm)	EARTH ROD (B) Ø (")	Stranded/Solid Circular Conductor Size (A) (mm ²)	Powder	Handle Clamp
CP-VS-127-16	12.7	1/2	16	P-90	HC-M
CP-VS-127-25	12.7	1/2	25	P-90	HC-M
CP-VS-127-35	12.7	1/2	35	P-90	HC-M
CP-VS-127-50	12.7	1/2	50	P-90	HC-M
CP-VS-127-70	12.7	1/2	70	P-90	HC-M
CP-VS-127-95	12.7	1/2	95	P-115	HC-M
CP-VS-127-120	12.7	1/2	120	P-150	HC-M
CP-VS-142-16	14.2	5/8	16	P-90	HC-M
CP-VS-142-25	14.2	5/8	25	P-90	HC-M
CP-VS-142-35	14.2	5/8	35	P-90	HC-M
CP-VS-142-50	14.2	5/8	50	P-90	HC-M
CP-VS-142-70	14.2	5/8	70	P-115	HC-M
CP-VS-142-95	14.2	5/8	95	P-115	HC-M
CP-VS-142-120	14.2	5/8	120	P-150	HC-M
CP-VS-142-150	14.2	5/8	150	P-200	HC-M
CP-VS-142-185	14.2	5/8	185	P-200	HC-M
CP-VS-142-240	14.2	5/8	240	P-250	HC-M
CP-VS-172-16	17.2	3/4	16	P-90	HC-M
CP-VS-172-25	17.2	3/4	25	P-90	HC-M
CP-VS-172-35	17.2	3/4	35	P-90	HC-M
CP-VS-172-50	17.2	3/4	50	P-115	HC-M
CP-VS-172-70	17.2	3/4	70	P-115	HC-M
CP-VS-172-95	17.2	3/4	95	P-115	HC-M
CP-VS-172-120	17.2	3/4	120	P-150	HC-M
CP-VS-172-150	17.2	3/4	150	P-200	HC-M
CP-VS-172-185	17.2	3/4	185	P-200	HC-M
CP-VS-172-240	17.2	3/4	240	P-250	HC-M
CP-VS-172-300	17.2	3/4	300	P-2x150	HC-L

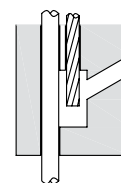

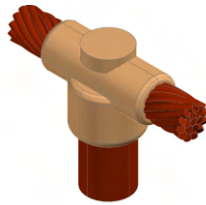

TEE TYPE (CP-T)

Code	CABLE TO EARTH ROD (T-Type)				
	Conforms to IEC 62561-1				
	EARTH ROD (B) Ø (mm)	EARTH ROD (B) Ø (")	Stranded/Solid Circular Conductor Size (A) (mm ²)	Powder	Handle Clamp
CP-T-127-16	12.7	1/2	16	P-90	HC-M
CP-T-127-25	12.7	1/2	25	P-90	HC-M
CP-T-127-35	12.7	1/2	35	P-90	HC-M
CP-T-127-50	12.7	1/2	50	P-90	HC-M
CP-T-127-70	12.7	1/2	70	P-90	HC-M
CP-T-127-95	12.7	1/2	95	P-115	HC-M
CP-T-127-120	12.7	1/2	120	P-150	HC-M
CP-T-142-16	14.2	5/8	16	P-90	HC-M
CP-T-142-25	14.2	5/8	25	P-90	HC-M
CP-T-142-35	14.2	5/8	35	P-90	HC-M
CP-T-142-50	14.2	5/8	50	P-90	HC-M
CP-T-142-70	14.2	5/8	70	P-115	HC-M
CP-T-142-95	14.2	5/8	95	P-115	HC-M
CP-T-142-120	14.2	5/8	120	P-150	HC-M
CP-T-142-150	14.2	5/8	150	P-200	HC-M
CP-T-142-185	14.2	5/8	185	P-200	HC-M
CP-T-142-240	14.2	5/8	240	P-250	HC-M
CP-T-172-16	17.2	3/4	16	P-90	HC-M
CP-T-172-25	17.2	3/4	25	P-90	HC-M
CP-T-172-35	17.2	3/4	35	P-90	HC-M
CP-T-172-50	17.2	3/4	50	P-115	HC-M
CP-T-172-70	17.2	3/4	70	P-115	HC-M
CP-T-172-95	17.2	3/4	95	P-115	HC-M
CP-T-172-120	17.2	3/4	120	P-150	HC-M
CP-T-172-150	17.2	3/4	150	P-200	HC-M
CP-T-172-185	17.2	3/4	185	P-200	HC-M
CP-T-172-240	17.2	3/4	240	P-250	HC-M
CP-T-172-300	17.2	3/4	300	P-2x150	HC-L

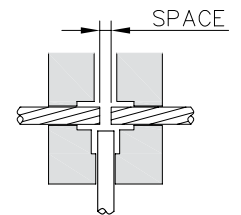



ONE SIDE HORIZONTAL (CP-AR)

Code	CABLE TO EARTH ROD (L-Type)				
	Conforms to IEC 62561-1				
	EARTH ROD (B) Ø (mm)	EARTH ROD (B) Ø (")	Stranded/Solid Circular Conductor Size (A) (mm ²)	Powder	Handle Clamp
CP-AR-127-16	12.7	1/2	16	P-65	HC-M
CP-AR-127-25	12.7	1/2	25	P-65	HC-M
CP-AR-127-35	12.7	1/2	35	P-65	HC-M
CP-AR-127-50	12.7	1/2	50	P-65	HC-M
CP-AR-127-70	12.7	1/2	70	P-90	HC-M
CP-AR-127-95	12.7	1/2	95	P-90	HC-M
CP-AR-127-120	12.7	1/2	120	P-90	HC-M
CP-AR-142-16	14.2	5/8	16	P-65	HC-M
CP-AR-142-25	14.2	5/8	25	P-65	HC-M
CP-AR-142-35	14.2	5/8	35	P-65	HC-M
CP-AR-142-50	14.2	5/8	50	P-90	HC-M
CP-AR-142-70	14.2	5/8	70	P-90	HC-M
CP-AR-142-95	14.2	5/8	95	P-90	HC-M
CP-AR-142-120	14.2	5/8	120	P-90	HC-M
CP-AR-142-150	14.2	5/8	150	P-115	HC-M
CP-AR-142-185	14.2	5/8	185	P-115	HC-M
CP-AR-142-240	14.2	5/8	240	P-150	HC-M
CP-AR-172-16	17.2	3/4	16	P-65	HC-M
CP-AR-172-25	17.2	3/4	25	P-65	HC-M
CP-AR-172-35	17.2	3/4	35	P-65	HC-M
CP-AR-172-50	17.2	3/4	50	P-90	HC-M
CP-AR-172-70	17.2	3/4	70	P-90	HC-M
CP-AR-172-95	17.2	3/4	95	P-90	HC-M
CP-AR-172-120	17.2	3/4	120	P-90	HC-M
CP-AR-172-150	17.2	3/4	150	P-115	HC-M
CP-AR-172-185	17.2	3/4	185	P-115	HC-M
CP-AR-172-240	17.2	3/4	240	P-150	HC-M
CP-AR-172-300	17.2	3/4	300	P-200	HC-M

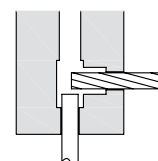

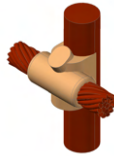

CROSS SIDE HORIZONTAL (CP-TS)



VERTICAL PARALLEL (PP-V)

CABLE TO EARTH ROD (CROSS SIDE HORIZONTAL)

Conforms to IEC 62561-1

Code	EARTH ROD (B) Ø (mm)	EARTH ROD (B) Ø (")	Stranded/Solid Circular Conductor Size (A) (mm ²)	Powder	Handle Clamp
CP-TS-127-16	12.7	1/2	16	P-90	HC-M
CP-TS-127-25	12.7	1/2	25	P-90	HC-M
CP-TS-127-35	12.7	1/2	35	P-90	HC-M
CP-TS-127-50	12.7	1/2	50	P-115	HC-M
CP-TS-127-70	12.7	1/2	70	P-115	HC-M
CP-TS-127-95	12.7	1/2	95	P-115	HC-M
CP-TS-127-120	12.7	1/2	120	P-150	HC-M
CP-TS-142-16	14.2	5/8	16	P-90	HC-M
CP-TS-142-25	14.2	5/8	25	P-90	HC-M
CP-TS-142-35	14.2	5/8	35	P-90	HC-M
CP-TS-142-50	14.2	5/8	50	P-115	HC-M
CP-TS-142-70	14.2	5/8	70	P-115	HC-M
CP-TS-142-95	14.2	5/8	95	P-115	HC-M
CP-TS-142-120	14.2	5/8	120	P-150	HC-M
CP-TS-142-150	14.2	5/8	150	P-150	HC-M
CP-TS-142-185	14.2	5/8	185	P-200	HC-M
CP-TS-142-240	14.2	5/8	240	P-2x200	HC-M
CP-TS-172-16	17.2	3/4	16	P-90	HC-M
CP-TS-172-25	17.2	3/4	25	P-90	HC-M
CP-TS-172-35	17.2	3/4	35	P-90	HC-M
CP-TS-172-50	17.2	3/4	50	P-115	HC-M
CP-TS-172-70	17.2	3/4	70	P-150	HC-M
CP-TS-172-95	17.2	3/4	95	P-150	HC-M
CP-TS-172-120	17.2	3/4	120	P-200	HC-M
CP-TS-172-150	17.2	3/4	150	P-250	HC-M
CP-TS-172-185	17.2	3/4	185	P-2x200	HC-L
CP-TS-172-240	17.2	3/4	240	P-2x250	HC-L
CP-TS-172-300	17.2	3/4	300	P-3x200	HC-L

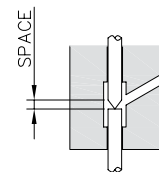
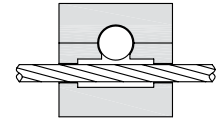

Leave a space of 5-6mm on cable and rod. Clamp the rod so it will not move.

PP-V (ROD TO ROD CONNECTION)	
143	P-200
146	P-200
58	P-200
183	P-150 x 2
34	P-150 x 2

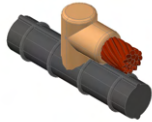

Cable to Reinforcing bar (CR-TP)

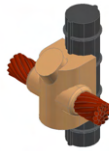

Cable to Reinforcing bar (CR-PH)



Cable to Reinforcing bar (CR-TL)

CABLE TO REINFORCING BAR (Single Parallel)				
Conforms to IEC 62561-1				
Code	Reinforcing bar Size (A) Ø (mm)	Stranded/Solid Circular Conductor Size (B) (mm²)	Powder	Handle Clamp
CR-TP-16	10-40	16	P-45	HC-M
CR-TP-25	10-40	25	P-45	HC-M
CR-TP-35	10-40	35	P-45	HC-M
CR-TP-50	10-40	50	P-90	HC-M
CR-TP-70	10-40	70	P-90	HC-M
CR-TP-95	10-40	95	P-90	HC-M
CR-TP-120	10-40	120	P-90	HC-M

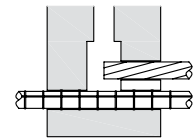

CABLE TO REINFORCING BAR (Cross Side Horizontal)				
Conforms to IEC 62561-1				
	Reinforcing bar Size (A) Ø (mm)	Stranded/Solid Circular Conductor Size (B) (mm²)	Powder	Handle Clamp
CR-PH-16	10-40	16	P-45	HC-M
CR-PH-25	10-40	25	P-45	HC-M
CR-PH-35	10-40	35	P-45	HC-M
CR-PH-50	10-40	50	P-90	HC-M
CR-PH-70	10-40	70	P-90	HC-M
CR-PH-95	10-40	95	P-90	HC-M
CR-PH-120	10-40	120	P-90	HC-M

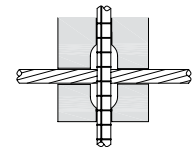

CABLE TO REINFORCING BAR (Tee Vertical)				
Conforms to IEC 62561-1				
	Reinforcing bar Size (A) Ø (mm)	Stranded/Solid Circular Conductor Size (B) (mm²)	Powder	Handle Clamp
CR-TL-16	10-40	16	P-45	HC-M
CR-TL-25	10-40	25	P-45	HC-M
CR-TL-35	10-40	35	P-45	HC-M
CR-TL-50	10-40	50	P-65	HC-M
CR-TL-70	10-40	70	P-90	HC-M
CR-TL-95	10-40	95	P-90	HC-M
CR-TL-120	10-40	120	P-115	HC-M

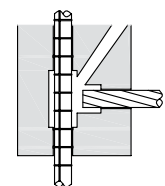



Cable to Reinforcing bar (CR-TH)

CABLE TO REINFORCING BAR (CR-TH)									
Code	Conforms to IEC 62561-1								
	Reinforcing Bar Size (A) Ø (mm)	Stranded/ Solid Circular Conductor Size (B) (mm²)	Powder	Handle Clamp		Reinforcing Bar Size (A) Ø (mm)	Stranded/ Solid Circular Conductor Size (B) (mm²)	Powder	Handle Clamp
CR-TH-16-H16	16	16	P-90	HC-M	CR-TH-20-H150	20	150	P-200	HC-M
CR-TH-16-H25	16	25	P-90	HC-M	CR-TH-20-H150	20	185	P-200	HC-M
CR-TH-16-H35	16	35	P-90	HC-M	CR-TH-20-H240	20	240	P-2x150	HC-M
CR-TH-16-H50	16	50	P-115	HC-M	CR-TH-20-H300	20	300	P-2x200	HC-M
CR-TH-16-H70	16	70	P-115	HC-M	CR-TH-25-H16	25	16	P-200	HC-M
CR-TH-16-H95	16	95	P-150	HC-M	CR-TH-25-H25	25	25	P-200	HC-M
CR-TH-16-H120	16	120	P-150	HC-M	CR-TH-25-H35	25	35	P-200	HC-M
CR-TH-16-H150	16	150	P-200	HC-M	CR-TH-25-H50	25	50	P-200	HC-M
CR-TH-16-H185	16	185	P-200	HC-M	CR-TH-25-H70	25	70	P-250	HC-M
CR-TH-16-H240	16	240	P-250	HC-M	CR-TH-25-H95	25	95	P-250	HC-M
CR-TH-16-H300	16	300	P-2x150	HC-M	CR-TH-25-H120	25	120	P-250	HC-M
CR-TH-18-H16	18	16	P-115	HC-M	CR-TH-25-H150	25	150	P-2x150	HC-M
CR-TH-18-H25	18	25	P-115	HC-M	CR-TH-25-H185	25	185	P-2x150	HC-L
CR-TH-18-H35	18	35	P-115	HC-M	CR-TH-25-H240	25	240	P-2x200	HC-L
CR-TH-18-H50	18	50	P-150	HC-M	CR-TH-25-H300	25	300	P-2x200	HC-L
CR-TH-18-H70	18	70	P-150	HC-M	CR-TH-30-H16	30	16	P-250	HC-M
CR-TH-18-H95	18	95	P-150	HC-M	CR-TH-30-H25	30	25	P-250	HC-M
CR-TH-18-H120	18	120	P-200	HC-M	CR-TH-30-H35	30	35	P-250	HC-M
CR-TH-18-H150	18	150	P-200	HC-M	CR-TH-30-H50	30	50	P-2x150	HC-M
CR-TH-18-H185	18	185	P-200	HC-M	CR-TH-30-H70	30	70	P-2x150	HC-M
CR-TH-18-H240	18	240	P-250	HC-M	CR-TH-30-H95	30	95	P-2x150	HC-L
CR-TH-18-H300	18	300	P-2x150	HC-M	CR-TH-30-H120	30	120	P-2x200	HC-L
CR-TH-20-H16	20	16	P-115	HC-M	CR-TH-30-H150	30	150	P-2x200	HC-L
CR-TH-20-H25	20	25	P-115	HC-M	CR-TH-30-H185	30	185	P-2x250	HC-L
CR-TH-20-H35	20	35	P-115	HC-M	CR-TH-30-H240	30	240	P-3x200	HC-L
CR-TH-20-H50	20	50	P-150	HC-M					
CR-TH-20-H70	20	70	P-200	HC-M					
CR-TH-20-H95	20	95	P-200	HC-M					
CR-TH-20-H120	20	120	P-200	HC-M					

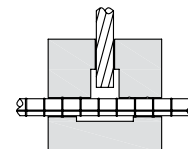

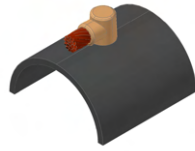

SINGLE PIPE HORIZONTAL (CT-TH)

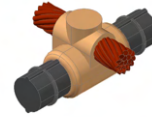

HORIZONTAL CROSS TAP (CR-XS)

Code **CABLE TO STEEL SURFACE & PIPE CT-TH (SINGLE HORIZONTAL)**

Conforms to IEC 62561-1

Code	Stranded/Solid Circular Conductor Size (A) (mm ²)	Pipe Size (B) Ø (mm)	Powder	Handle Clamp
CT-TH-2.5A	2.5	<125	P-15	HC-M
CT-TH-2.5B	2.5	>125	P-15	HC-M
CT-TH-4A	4	<125	P-15	HC-M
CT-TH-4B	4	>125	P-15	HC-M
CT-TH-6A	6	<125	P-15	HC-M
CT-TH-6B	6	>125	P-15	HC-M
CT-TH-10A	10	<125	P-25	HC-M
CT-TH-10B	10	>125	P-25	HC-M
CT-TH-16A	16	<125	P-45	HC-L
CT-TH-16B	16	>125	P-45	HC-L
CT-TH-25A	25	<70	P-25	HC-M
CT-TH-25B	25	70-165	P-25	HC-M
CT-TH-25C	25	>165	P-25	HC-M
CT-TH-35A	35	<70	P-45	HC-L
CT-TH-35B	35	70-165	P-45	HC-L
CT-TH-35C	35	165-250	P-45	HC-L
CT-TH-35D	35	>250	P-45	HC-L
CT-TH-50A	50	<70	P-45	HC-L
CT-TH-50B	50	70-165	P-45	HC-L
CT-TH-50C	50	165-250	P-45	HC-L
CT-TH-50D	50	>250	P-45	HC-L
CT-TH-70A	70	<70	P-65	HC-L
CT-TH-70B	70	70-165	P-65	HC-L
CT-TH-70C	70	165-250	P-65	HC-L
CT-TH-50D	70	>250	P-65	HC-L

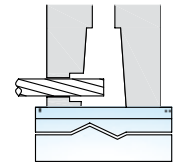
Code **CABLE TO REINFORCING BAR (CR-XS)**

Code	Reinforcing bar Size (A) Ø (mm)	Stranded/Solid Circular Conductor Size (B) (mm ²)	Powder	Handle Clamp
CR-XS-1650	16	50	P-150	HC-L
CR-XS-1670	16	70	P-150	HC-L
CR-XS-16120	16	120	P-200	HC-L
CR-XS-16150	16	150	P-200	HC-L
CR-XS-2070	20	70	P-150	HC-L
CR-XS-2095	20	95	P-200	HC-L
CR-XS-20185	20	185	P-250	HC-L
CR-XS-20240	20	240	P-150 x 2	HC-L

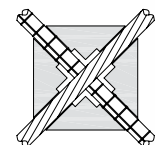



STRAIGHT INCLINED (CH-TF)



SINGLE DESCENDING (CH-VI)

Code **CABLE TO STEEL SURFACE & PIPE CH-TF (STRAIGHT INCLINED)**

Conforms to IEC 62561-1

Code	Stranded/Solid Circular Conductor Size (A) (mm ²)	Powder	Handle Clamp
CH-TF-16	16	P-45	HC-M
CH-TF-25	25	P-45	HC-M
CH-TF-35	35	P-45	HC-M
CH-TF-50	50	P-65	HC-M
CH-TF-70	70	P-90	HC-M
CH-TF-95	95	P-115	HC-M
CH-TF-120	120	P-115	HC-M
CH-TF-150	150	P-115	HC-M
CH-TF-185	185	P-200	HC-M
CH-TF-240	240	P-200	HC-M
CH-TF-300	300	P-250	HC-M

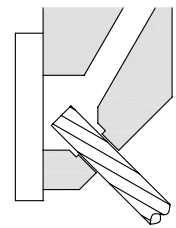

CABLE TO STEEL SURFACE & PIPE CH-VI (SINGLE DESCENDING)

Conforms to IEC 62561-1

Code	Stranded/Solid Circular Conductor Size (A) (mm ²)	Powder	Handle Clamp
CH-VI-16	16	P-45	HC-M
CH-VI-25	25	P-45	HC-M
CH-VI-35	35	P-45	HC-M
CH-VI-50	50	P-65	HC-M
CH-VI-70	70	P-90	HC-M
CH-VI-95	95	P-115	HC-M
CH-VI-120	120	P-115	HC-M
CH-VI-150	150	P-150	HC-M
CH-VI-185	185	P-200	HC-M
CH-VI-240	240	P-200	HC-M
CH-VI-300	300	P-250	HC-M

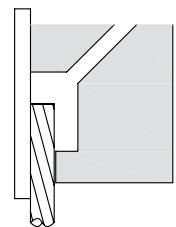

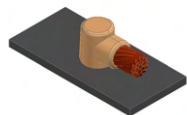

SINGLE HORIZONTAL (CH-TH)

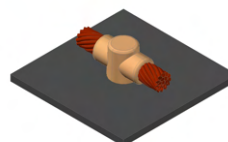

DOUBLE HORIZONTAL (CH-PPH)

Code **CABLE TO STEEL SURFACE & PIPE CH-TH (SINGLE HORIZONTAL)**

Conforms to IEC 62561-1

Code	Stranded/Solid Circular Conductor Size (A) (mm ²)	Powder	Handle Clamp
CH-TH-16	16	P-45	HC-M
CH-TH-25	25	P-45	HC-M
CH-TH-35	35	P-45	HC-M
CH-TH-50	50	P-45	HC-M
CH-TH-70	70	P-65	HC-M
CH-TH-95	95	P-90	HC-M
CH-TH-120	120	P-115	HC-L
CH-TH-150	150	P-150	HC-L
CH-TH-185	185	P-200	HC-L
CH-TH-240	240	P-200	HC-L
CH-TH-300	300	P-250	HC-L

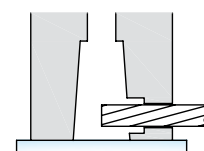

CABLE TO STEEL SURFACE & PIPE CH-PPH (DOUBLE HORIZONTAL)

Conforms to IEC 62561-1

Code	Stranded/Solid Circular Conductor Size (A) (mm ²)	Powder	Handle Clamp
CH-PPH-16	16	P-45	HC-M
CH-PPH-25	25	P-45	HC-M
CH-PPH-35	35	P-45	HC-M
CH-PPH-50	50	P-90	HC-M
CH-PPH-70	70	P-115	HC-M
CH-PPH-95	95	P-115	HC-M
CH-PPH-120	120	P-150	HC-M
CH-PPH-150	150	P-200	HC-M
CH-PPH-185	185	P-250	HC-M
CH-PPH-240	240	P-2x150	HC-M
CH-PPH-300	300	P-250	HC-L

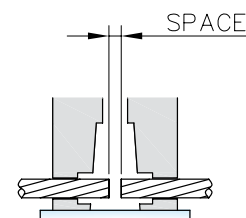

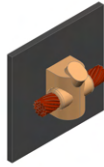

DOUBLE VERTICAL-(CH-TVD/CH-TVI)



SINGLE ASCENDING (CH-VS)

Code **CABLE TO STEEL SURFACE & PIPE CH-TVD/CH-TVI (DOUBLE VERTICAL)**

Conforms to IEC 62561-1

Code	Stranded/Solid Circular Conductor Size (A) (mm ²)	Powder	Handle Clamp
CH-TVD-16	16	P-45	HC-M
CH-TVD-25	25	P-45	HC-M
CH-TVD-35	35	P-45	HC-M
CH-TVD-50	50	P-65	HC-M
CH-TVD-70	70	P-115	HC-M
CH-TVD-95	95	P-150	HC-M
CH-TVD-120	120	P-150	HC-M
CH-TVD-150	150	P-200	HC-L
CH-TVD-185	185	P-250	HC-L
CH-TVD-240	240	P-2x150	HC-L
CH-TVD-300	300	P-2x200	HC-L

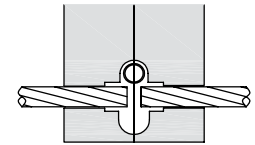

CABLE TO STEEL SURFACE & PIPE CH-VS (SINGLE ASCENDING)

Conforms to IEC 62561-1

Code	Stranded/Solid Circular Conductor Size (A) (mm ²)	Powder	Handle Clamp
CH-VS-16	16	P-65	HC-M
CH-VS-25	25	P-65	HC-M
CH-VS-35	35	P-65	HC-M
CH-VS-50	50	P-90	HC-M
CH-VS-70	70	P-150	HC-M
CH-VS-95	95	P-200	HC-M
CH-VS-120	120	P-200	HC-M
CH-VS-150	150	P-250	HC-M
CH-VS-185	185	P-2x150	HC-M
CH-VS-240	240	P-2x150	HC-M
CH-VS-300	300	P-2x200	HC-L

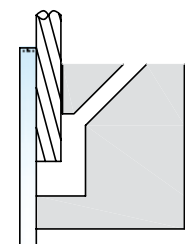



VERTICAL PARALLEL (CH-PVV)



ONE SIDE SINGLE (CH-PVH)

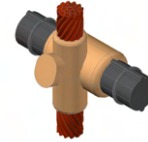

CROSS VERTICAL (CR-PV)

Code **CABLE TO STEEL SURFACE & PIPE CH-PVV (VERTICAL PARALLEL)**

Conforms to IEC 62561-1

Code	Stranded/Solid Circular Conductor Size (A) (mm ²)	Powder	Handle Clamp
CH-PVV-16	16	P-45	HC-M
CH-PVV-25	25	P-45	HC-M
CH-PVV-35	35	P-45	HC-M
CH-PVV-50	50	P-90	HC-M
CH-PVV-70	70	P-115	HC-M
CH-PVV-95	95	P-115	HC-M
CH-PVV-120	120	P-150	HC-M
CH-PVV-150	150	P-200	HC-M
CH-PVV-185	185	P-250	HC-M
CH-PVV-240	240	P-150x2	HC-L
CH-PVV-300	300	P-200x2	HC-L

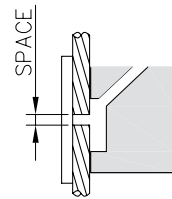

Code **CABLE TO STEEL SURFACE & PIPE CH-PVH (ONE SIDE SINGLE)**

Code	Stranded/Solid Circular Conductor Size (A) (mm ²)	Powder	Handle Clamp
CH-PVH-25	25	P-65	HC-M
CH-PVH-35	35	P-90	HC-M
CH-PVH-50	50	P-115	HC-M
CH-PVH-70	70	P-115	HC-M
CH-PVH-95	95	P-150	HC-M
CH-PVH-120	120	P-150	HC-M
CH-PVH-150	150	P-200	HC-M
CH-PVH-185	185	P-250	HC-M
CH-PVH-240	240	P-150 x2	HC-M

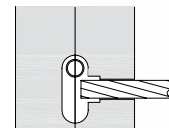

Code **CABLE TO REINFORCING BAR (CR-PV)**

Code	Reinforcing bar Size (A) Ø (mm)	Stranded/Solid Circular Conductor Size (B) (mm ²)	Powder	Handle Clamp
CR-PV-1650	16	50	P-150	HC-M
CR-PV-1670	16	70	P-150	HC-M
CR-PV-16120	16	120	P-200	HC-M
CR-PV-16150	16	150	P-200	HC-M
CR-PV-2070	20	70	P-150	HC-M
CR-PV-2095	20	95	P-200	HC-M
CR-PV-20185	20	185	P-250	HC-M
CR-PV-20240	20	240	P-150 x 2	HC-M

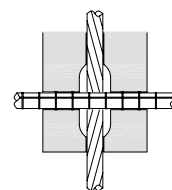

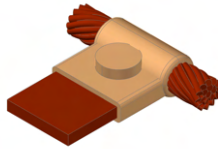

TEE HORIZONTAL (CPL-T)

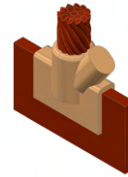

TEE VERTICAL (CPL-VS)

Code **CABLE TO BAR (CPL - T)**

Conforms to IEC 62561-1

Code	Stranded/Solid Circular Conductor Size (A) (mm ²)	Flat Tape Conductor Size (B) (mm)	Powder	Handle Clamp
CPL-T-16-203	16	20x3	P-45	HC-M
CPL-T-16-253	16	25x3	P-65	HC-M
CPL-T-25-203	25	20x3	P-45	HC-M
CPL-T-25-253	25	25x3	P-65	HC-M
CPL-T-35-203	35	20x3	P-45	HC-M
CPL-T-35-253	35	25x3	P-65	HC-M
CPL-T-50-203	50	20x3	P-65	HC-M
CPL-T-50-253	50	25x3	P-65	HC-M
CPL-T-70-254	70	25x4	P-90	HC-M
CPL-T-70-256	70	25x6	P-115	HC-M
CPL-T-70-253	70	25x3	P-115	HC-M
CPL-T-95-254	95	25x4	P-150	HC-M
CPL-T-95-256	95	25x6	P-150	HC-M
CPL-T-120-254	120	25x4	P-150	HC-M
CPL-T-120-256	120	25x6	P-200	HC-M
CPL-T-150256	150	25x6	P-200	HC-M
CPL-T-150305	150	30x5	P-200	HC-M
CPL-T-150-405	150	40x5	P-250	HC-M
CPL-T-185-316	185	31x6	P-250	HC-M
CPL-T-185-405	185	40x5	P-250	HC-M
CPL-T-185-505	185	50x5	P-2x150	HC-L
CPL-T-240-505	240	50x5	P-2x150	HC-L
CPL-T-240-506	240	50x6	P-2x200	HC-L
CPL-T-300-506	300	50x6	P-2x250	HC-L

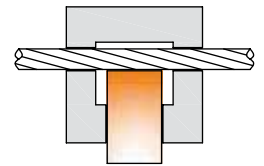

Code **CABLE TO BAR (CPL - VS)**

Code	Stranded/Solid Circular Conductor Size (B) (mm ²)	Flat Tape Conductor Size (A) (mm)	Powder	Handle Clamp
CPL-VS-25-253	25	25x3	P-90	HC-M
CPL-VS-35-253	35	25x3	P-90	HC-M
CPL-VS-50-253	50	25x3	P-115	HC-M
CPL-VS-70-253	70	25x3	P-115	HC-M
CPL-VS-95-253	95	25x3	P-150	HC-M
CPL-VS-120-305	120	30x5	P-200	HC-M
CPL-VS-150-405	150	40x5	P-250	HC-M
CPL-VS-240-505	240	50x5	P-150 x 2	HC-M

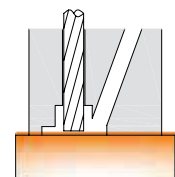

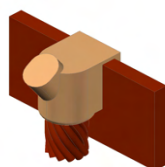

TEE DESCENDING (CPL-VI)

Code	CABLE TO BAR (TEE TYPE)			
	Conforms to IEC 62561-1			
	Stranded/Solid Circular Conductor Size (B) (mm ²)	Flat Tape Conductor Size (A) (mm)	Powder	Handle Clamp
CPL-VI-16-203	16	20x3	P-45	HC-M
CPL-VI-16-253	16	25x3	P-45	HC-M
CPL-VI-25-203	25	20x3	P-45	HC-M
CPL-VI-25-253	25	25x3	P-45	HC-M
CPL-VI-35-203	35	20x3	P-45	HC-M
CPL-VI-35-253	35	25x3	P-45	HC-M
CPL-VI-50-203	50	20x3	P-45	HC-M
CPL-VI-50-253	50	25x3	P-45	HC-M
CPL-VI-70-254	70	25x4	P-65	HC-M
CPL-VI-70-256	70	25x6	P-65	HC-M
CPL-VI-70-253	70	25x3	P-90	HC-M
CPL-VI-95-254	95	25x4	P-90	HC-M
CPL-VI-95-256	95	25x6	P-115	HC-M
CPL-VI-120-254	120	25x4	P-115	HC-M
CPL-VI-120-256	120	25x6	P-115	HC-M
CPL-VI-150-256	150	25x6	P-115	HC-M
CPL-VI-150-305	150	30x5	P-115	HC-M
CPL-VI-150-405	150	40x5	P-115	HC-M
CPL-VI-185-316	185	31x6	P-150	HC-M
CPL-VI-185-405	185	40x5	P-150	HC-M
CPL-VI-185-505	185	50x5	P-150	HC-M
CPL-VI-240-505	240	50x5	P-200	HC-M
CPL-VI-240-506	240	50x6	P-250	HC-M
CPL-VI-300-506	300	50x6	P-2x150	HC-L

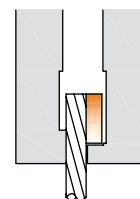

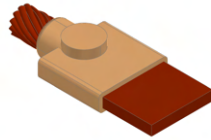

STRAIGHT WIDTH (CPL-L)

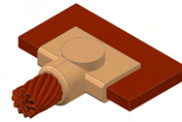

TAPE TEE HORIZONTAL (CPL-H)

Code	CABLE TO BAR (STRAIGHT WIDTH)			
	Conforms to IEC 62561-1			
	Stranded/Solid Circular Conductor Size (B) (mm ²)	Flat Tape Conductor Size (A) (mm)	Powder	Handle Clamp
CPL-L-16-203	16	20x3	P-45	HC-M
CPL-L-16-253	16	25x3	P-45	HC-M
CPL-L-25-203	25	20x3	P-32	HC-M
CPL-L-25-253	25	25x3	P-45	HC-M
CPL-L-35-203	35	20x3	P-45	HC-M
CPL-L-35-253	35	25x3	P-45	HC-M
CPL-L-50-203	50	20x3	P-45	HC-M
CPL-L-50-253	50	25x3	P-65	HC-M
CPL-L-70-254	70	25x4	P-65	HC-M
CPL-L-70-256	70	25x6	P-65	HC-M
CPL-L-70-253	70	25x3	P-65	HC-M
CPL-L-95-254	95	25x4	P-90	HC-M
CPL-L-95-256	95	25x6	P-90	HC-M
CPL-L-120-254	120	25x4	P-90	HC-M
CPL-L-120-256	120	25x6	P-115	HC-M
CPL-L-150-256	150	25x6	P-115	HC-M
CPL-L-150-305	150	30x5	P-115	HC-M
CPL-L-150-405	150	40x5	P-150	HC-M
CPL-L-185-316	185	31x6	P-150	HC-M
CPL-L-185-405	185	40x5	P-150	HC-M
CPL-L-185-505	185	50x5	P-200	HC-L
CPL-L-240-505	240	50x5	P-200	HC-L
CPL-L-240-506	240	50x6	P-2x150	HC-L
CPL-L-300-506	300	50x6	P-2x150	HC-L

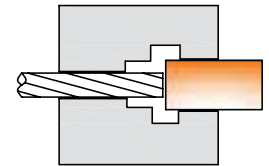

Code	CABLE TO BAR (CPL - H)			
	Stranded /Solid Circular Conductor Size (A) (mm ²)	Flat Tape Conductor Size (B) (mm)	Powder	Handle Clamp
CPL-H-25-203	25	20x3	P-45	HC-M
CPL-H-35-253	35	25x3	P-45	HC-M
CPL-H-50-253	50	25x3	P-65	HC-M
CPL-H-70-253	70	25x3	P-90	HC-M
CPL-H-95-253	95	25x3	P-90	HC-M
CPL-H-120-253	120	25x3	P-115	HC-M
CPL-H-150-253	150	20x3	P-115	HC-M
CPL-H-240-505	240	50x5	P-250	HC-M

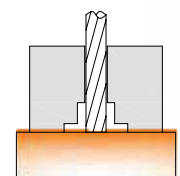

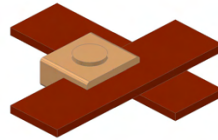

CROSS HORIZONTAL (PL-X)

Code	BAR TO BAR (CROSS)			
	Conforms to IEC 62561-1			
	Flat Tape Conductor Size (A) (mm)	Flat Tape Conductor Size (B) (mm)	Powder	Handle Clamp
PL-X-203-203	20x3	20x3	P-65	HC-M
PL-X-253-253	25x3	25x3	P-65	HC-M
PL-X-254-254	25x4	25x4	P-90	HC-M
PL-X-256-256	25x6	25x6	P-115	HC-M
PL-X-302-302	30x2	30x2	P-65	HC-M
PL-X-303-303	30x3	30x3	P-115	HC-M
PL-X-304-304	30x4	30x4	P-115	HC-M
PL-X-305-305	30x5	30x5	P-115	HC-M
PL-X-313-313	31x3	31x3	P-115	HC-M
PL-X-316-316	31x6	31x6	P-115	HC-M
PL-X-383-383	38x3	38x3	P-150	HC-M
PL-X-385-385	38x5	38x5	P-150	HC-M
PL-X-386-386	38x6	38x6	P-200	HC-M
PL-X-403-403	40x3	40x3	P-200	HC-M
PL-X-404-404	40x4	40x4	P-200	HC-M
PL-X-405-405	40x5	40x5	P-200	HC-M
PL-X-406-406	40x6	40x6	P-200	HC-M
PL-X-503-503	50x3	50x3	P-200	HC-L
PL-X-504-504	50x4	50x4	P-200	HC-L
PL-X-505-505	50x5	50x5	P-200	HC-L
PL-X-506-506	50x6	50x6	P-200	HC-L

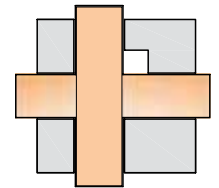

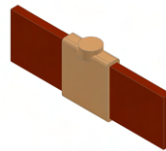

STRAIGHT HEIGHT (PL-LV)

Code	BAR TO BAR (STRAIGHT TYPE)		
	Conforms to IEC 62561-1		
	Flat Tape Conductor Size (A) (mm)	Powder	Handle Clamp
PL-LV-203	20x3	P-45	HC-M
PL-LV-253	25x3	P-65	HC-M
PL-LV-254	25x4	P-90	HC-M
PL-LV-256	25x6	P-150	HC-M
PL-LV-302	30x2	P-65	HC-M
PL-LV-303	30x3	P-90	HC-M
PL-LV-304	30x4	P-115	HC-M
PL-LV-305	30x5	P-115	HC-M
PL-LV-313	31x3	P-90	HC-M
PL-LV-316	31x6	P-150	HC-M
PL-LV-383	38x3	P-115	HC-M
PL-LV-385	38x5	P-150	HC-M
PL-LV-386	38x6	P-200	HC-M
PL-LV-403	40x3	P-115	HC-M
PL-LV-404	40x4	P-150	HC-M
PL-LV-405	40x5	P-150	HC-M
PL-LV-406	40x6	P-200	HC-M
PL-LV-503	50x3	P-150	HC-M
PL-LV-504	50x4	P-200	HC-M
PL-LV-505	50x5	P-200	HC-M
PL-LV-506	50x6	P-250	HC-M

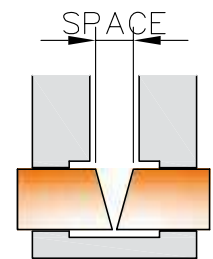

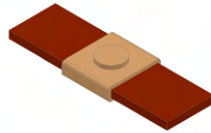

STRAIGHT WIDTH (PL-LH)

Code **BAR TO BAR (STRAIGHT WIDTH TYPE)**

Conforms to IEC 62561-1

Code	Flat Tape Conductor Size (A) (mm)	Powder	Handle Clamp
PL-LH-203	20x3	P-45	HC-M
PL-LH-253	25x3	P-65	HC-M
PL-LH-254	25x4	P-90	HC-M
PL-LH-256	25x6	P-115	HC-M
PL-LH-302	30x2	P-65	HC-M
PL-LH-303	30x3	P-65	HC-M
PL-LH-304	30x4	P-90	HC-M
PL-LH-305	30x5	P-115	HC-M
PL-LH-313	31x3	P-65	HC-M
PL-LH-316	31x6	P-150	HC-M
PL-LH-383	38x3	P-90	HC-M
PL-LH-385	38x5	P-150	HC-M
PL-LH-386	38x6	P-200	HC-M
PL-LH-403	40x3	P-90	HC-M
PL-LH-404	40x4	P-115	HC-M
PL-LH-405	40x5	P-150	HC-M
PL-LH-406	40x6	P-200	HC-M
PL-LH-503	50x3	P-150	HC-L
PL-LH-504	50x4	P-200	HC-L
PL-LH-505	50x5	P-200	HC-L
PL-LH-506	50x6	P-250	HC-L

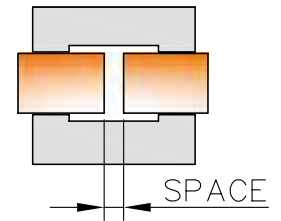

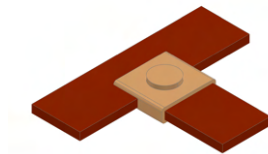

TEE HORIZONTAL (PL-TH)

Code	BAR TO BAR (TEE TYPE)			
	Conforms to IEC 62561-1			
	Flat Tape Conductor Size (A) (mm)	Flat Tape Conductor Size (B) (mm)	Powder	Handle Clamp
PL-TH-203-203	20x3	20x3	P-45	HC-M
PL-TH-253-253	25x3	25x3	P-65	HC-M
PL-TH-254-254	25x4	25x4	P-90	HC-M
PL-TH-256-256	25x6	25x6	P-150	HC-M
PL-TH-302-302	30x2	30x2	P-65	HC-M
PL-TH-303-303	30x3	30x3	P-90	HC-M
PL-TH-304-304	30x4	30x4	P-115	HC-M
PL-TH-305-305	30x5	30x5	P-115	HC-M
PL-TH-313-313	31x3	31x3	P-90	HC-M
PL-TH-316-316	31x6	31x6	P-150	HC-M
PL-TH-383-383	38x3	38x3	P-115	HC-M
PL-TH-385-385	38x5	38x5	P-150	HC-M
PL-TH-386-386	38x6	38x6	P-200	HC-M
PL-TH-403-403	40x3	40x3	P-115	HC-M
PL-TH-404-404	40x4	40x4	P-150	HC-M
PL-TH-405-405	40x5	40x5	P-150	HC-M
PL-TH-406-406	40x6	40x6	P-200	HC-M
PL-TH-503-503	50x3	50x3	P-150	HC-M
PL-TH-504-504	50x4	50x4	P-200	HC-M
PL-TH-505-505	50x5	50x5	P-200	HC-M
PL-TH-506-506	50x6	50x6	P-250	HC-M

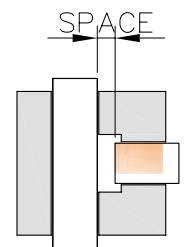

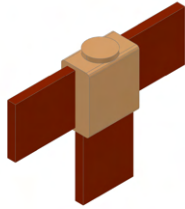

TEE VERTICAL (PL-TV)

Code	BAR TO BAR (TEE VERTICAL)			
	Conforms to IEC 62561-1			
	Flat Tape Conductor Size (A) (mm)	Flat Tape Conductor Size (B) (mm)	Powder	Handle Clamp
PL-TV-203-203	20x3	20x3	P-65	HC-M
PL-TV-253-253	25x3	25x3	P-65	HC-M
PL-TV-254-254	25x4	25x4	P-90	HC-M
PL-TV-256-256	25x6	25x6	P-150	HC-M
PL-TV-302-302	30x2	30x2	P-65	HC-M
PL-TV-303-303	30x3	30x3	P-90	HC-M
PL-TV-304-304	30x4	30x4	P-115	HC-M
PL-TV-305-305	30x5	30x5	P-115	HC-M
PL-TV-313-313	31x3	31x3	P-115	HC-M
PL-TV-316-316	31x6	31x6	P-200	HC-M
PL-TV-383-383	38x3	38x3	P-115	HC-M
PL-TV-385-385	38x5	38x5	P-150	HC-M
PL-TV-386-386	38x6	38x6	P-200	HC-M
PL-TV-403-403	40x3	40x3	P-115	HC-M
PL-TV-404-404	40x4	40x4	P-150	HC-M
PL-TV-405-405	40x5	40x5	P-150	HC-M
PL-TV-406-406	40x6	40x6	P-200	HC-M
PL-TV-503-503	50x3	50x3	P-200	HC-M
PL-TV-504-504	50x4	50x4	P-200	HC-M
PL-TV-505-505	50x5	50x5	P-200	HC-M
PL-TV-506-506	50x6	50x6	P-250	HC-M

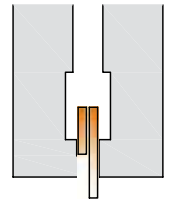



STRAIGHT VERTICAL (PL-V)

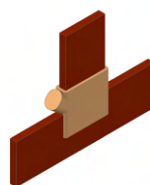

UPSIDE DOWN (PL-TS)

Code BAR TO BAR (STRAIGHT VERTICAL)

Conforms to IEC 62561-1

Code	Flat Tape Conductor Size (A) (mm)	Powder	Handle Clamp
PL-V-203	20x3	P-45	HC-M
PL-V-253	25x3	P-65	HC-M
PL-V-254	25x4	P-90	HC-M
PL-V-256	25x6	P-150	HC-M
PL-V-302	30x2	P-65	HC-M
PL-V-303	30x3	P-90	HC-M
PL-V-304	30x4	P-115	HC-M
PL-V-305	30x5	P-115	HC-M
PL-V-313	31x3	P-90	HC-M
PL-V-316	31x6	P-150	HC-M
PL-V-383	38x3	P-115	HC-M
PL-V-385	38x5	P-150	HC-M
PL-V-386	38x6	P-200	HC-M
PL-V-403	40x3	P-115	HC-M
PL-V-404	40x4	P-150	HC-M
PL-V-405	40x5	P-150	HC-M
PL-V-406	40x6	P-200	HC-M
PL-V-503	50x3	P-150	HC-M
PL-V-504	50x4	P-200	HC-M
PL-V-505	50x5	P-200	HC-M
PL-V-506	50x6	P-250	HC-M

Code BAR TO BAR (UPSIDE DOWN)

Conforms to IEC 62561-1

Code	Flat Tape Conductor Size (A) (mm)	Flat Tape Conductor Size (B) (mm)	Powder	Handle Clamp
PL-TS-203-203	20x3	20x3	P-65	HC-M
PL-TS-253-253	25x3	25x3	P-65	HC-M
PL-TS-254-254	25x4	25x4	P-90	HC-M
PL-TS-256-256	25x6	25x6	P-150	HC-M
PL-TS-302-302	30x2	30x2	P-65	HC-M
PL-TS-303-303	30x3	30x3	P-90	HC-M
PL-TS-304-304	30x4	30x4	P-115	HC-M
PL-TS-305-305	30x5	30x5	P-115	HC-M
PL-TS-313-313	31x3	31x3	P-115	HC-M
PL-TS-31-6316	31x6	31x6	P-200	HC-M
PL-TS-383-383	38x3	38x3	P-115	HC-M
PL-TS-385-385	38x5	38x5	P-150	HC-M
PL-TS-386-386	38x6	38x6	P-200	HC-M
PL-TS-403-403	40x3	40x3	P-115	HC-M
PL-TS-404-404	40x4	40x4	P-150	HC-M
PL-TS-405-405	40x5	40x5	P-150	HC-M
PL-TS-406-406	40x6	40x6	P-200	HC-M
PL-TS-503-503	50x3	50x3	P-200	HC-M
PL-TS-504-504	50x4	50x4	P-200	HC-M
PL-TS-505-505	50x5	50x5	P-200	HC-M
PL-TS-506-506	50x6	50x6	P-250	HC-M

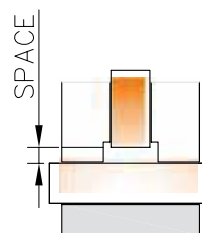

NOTE: SEICO is manufacturing and providing various special types of Moulds as per clients / Project demands which are not included in this section. Kindly contact our SEICO Sales Office for Special type of demands.

SEICOWELD ACCESSORIES

MOULDS



This is made of graphite block, a heat-resistant material which normally welds an average of 70 to 100 connections under normal size.

HANDLE CLAMP (HCM/HCL)



This is used for opening and closing the mould. The handle clamp(HC) is of two types depending on the mould size (HC-M & HC-L).

HANDLE CLAMP (HCM1)



The handle clamp with chain is designed to fit moulds into steel pipe, horizontal and vertical positions.

IGNITION LIGHTER (IL)



For Safety and quick ignition of the starting powder. Standard flint replacements are suitable. (IL)

TAPE CLEANING BRUSH (CCB/TCB)



For easy cleaning of conductor/Tape before welding. (CCB)

MOULD BRUSH (MB)



For cleaning safely the inner part of the mould. (MB)

MOULD SCRAPER (MS)



For removing easily the stags which accumulated in the crucible. (MS)

NOTE: All pictures shown in the catalogue are for illustration purpose only. Actual product may vary due to product enhancement.



NOTES

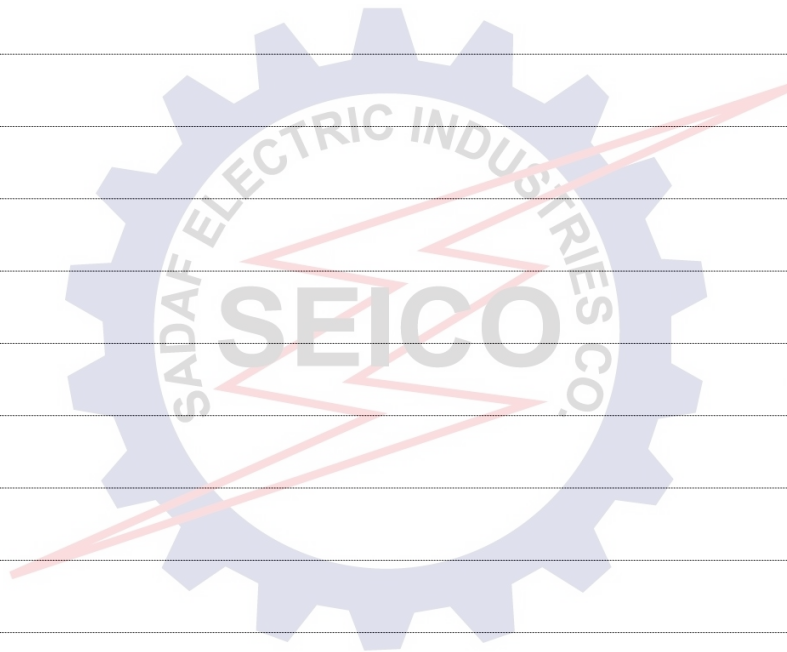

NOTES

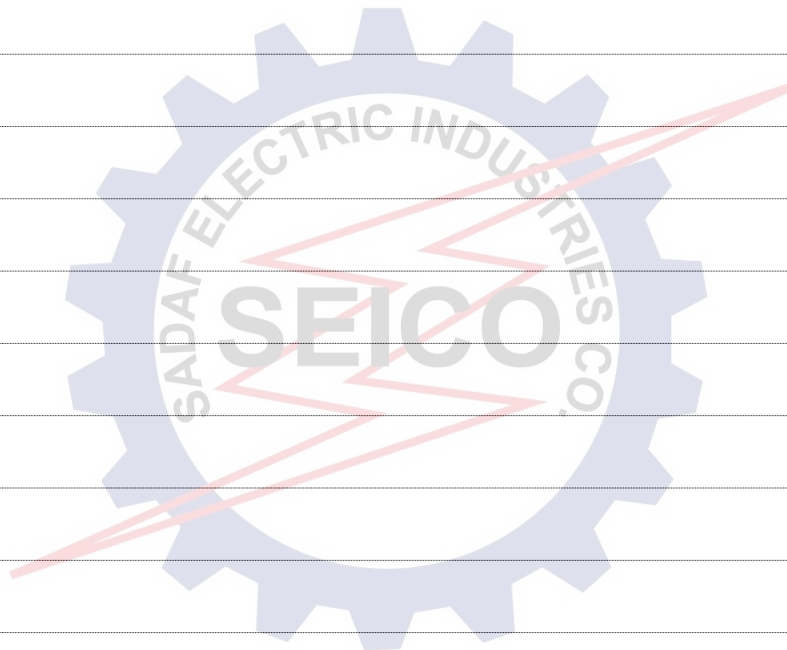



NOTES

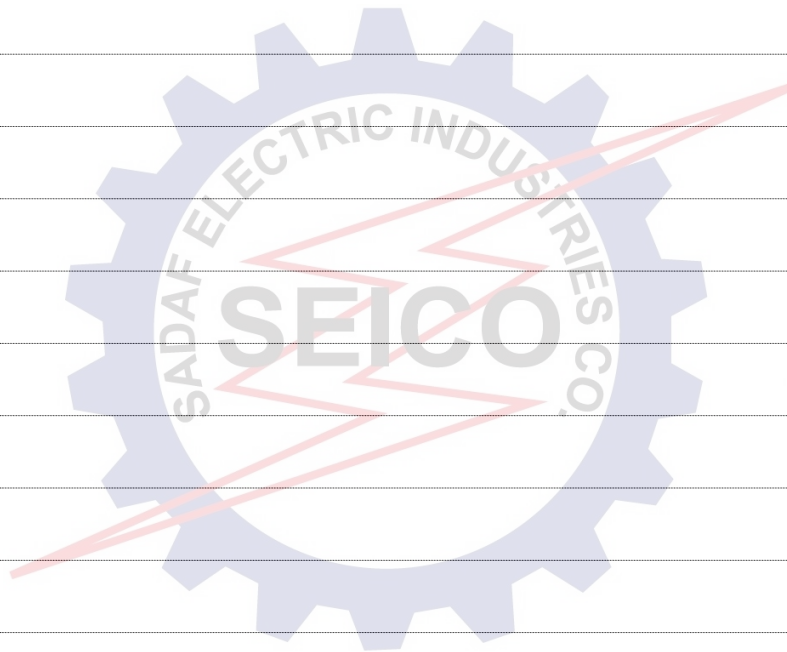

NOTES

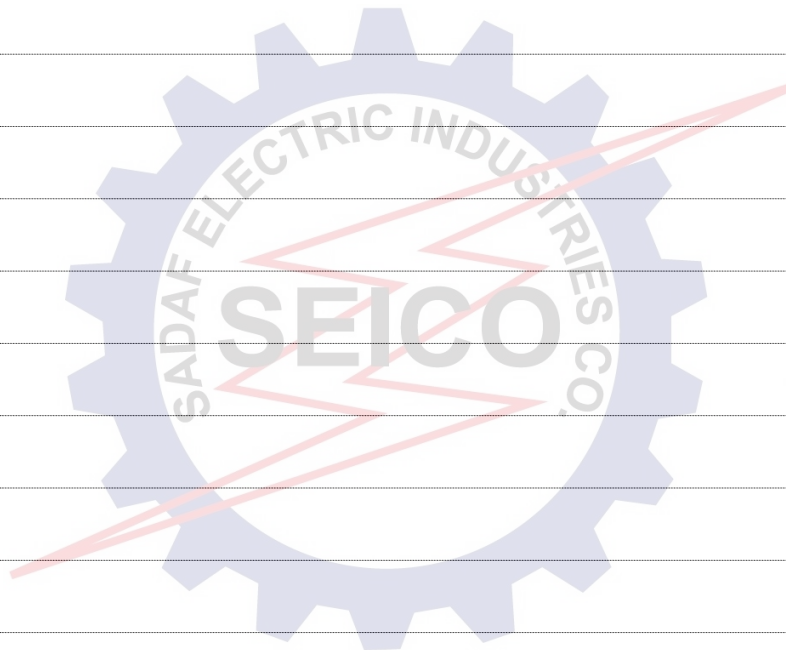



Sales and Technical Hot-line Inquiries: Please call us at **+96612 6080006**
SEICO Factory

Jeddah - Kingdom of Saudi Arabia
Industrial City - Zone 5,
P.O. Box 16943, Jeddah 21474

Tel.: +966126080006
E-mail: sales@seico-sa.com
www.seico-sa.com



**QR CODE OF OUR
OFFICIAL WEBSITE**



SADAF ELECTRIC INDUSTRIES CO.

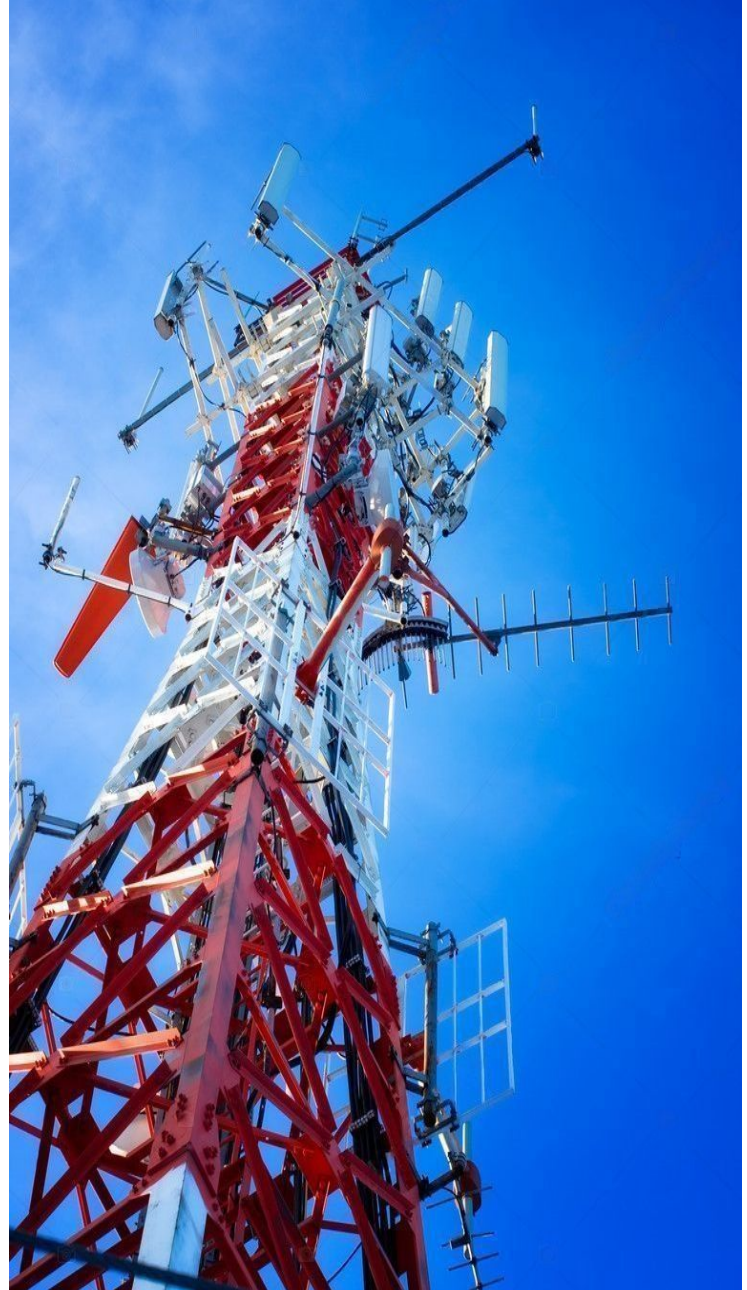

SADAF ELECTRIC INDUSTRIE CO. (SEICO)

EARTHING AND LIGHTNING PROTECTION (MAIN CATALOGUE)

FOLLOW US ON

www.seico-sa.com

